

GSS

Miniature Fuses



Cylindrical fuses:	5x20 · 6.3x32 · 5x25 5x30 · 8x40 · 8x50 8x85 · 10x85 · 8x120 · 8x150
Axial leads:	5 x 20 · 6.3 x 32
2 pin fuses:	KS, Ø 8.4 mm
SMD fuses:	0402 · 0603 · 0805 · 1206 2.6x6.1 · 4.5x8 · 4.5x16
Voltage ratings:	25V - 10kV
Operation class:	aR very quick acting F fast acting T time lag M medium time lag FF very fast acting TT long time lag T/D time delay gPV photovoltaic

Approvals:



Standards:

IEC 60127
DIN VDE 0820
CEE4
UL 248-14
UL 512
CSA-C22.2 No. 248.14
IEC 60269

Features and Benefits



High interrupt ratings, up to 200kA



Ratings available for semiconductor protection



Fuse holders, fuse bases and fuse clips available

Miniature Fuses

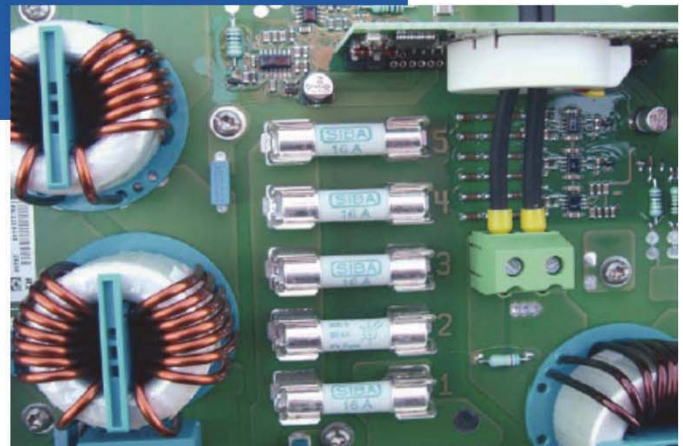
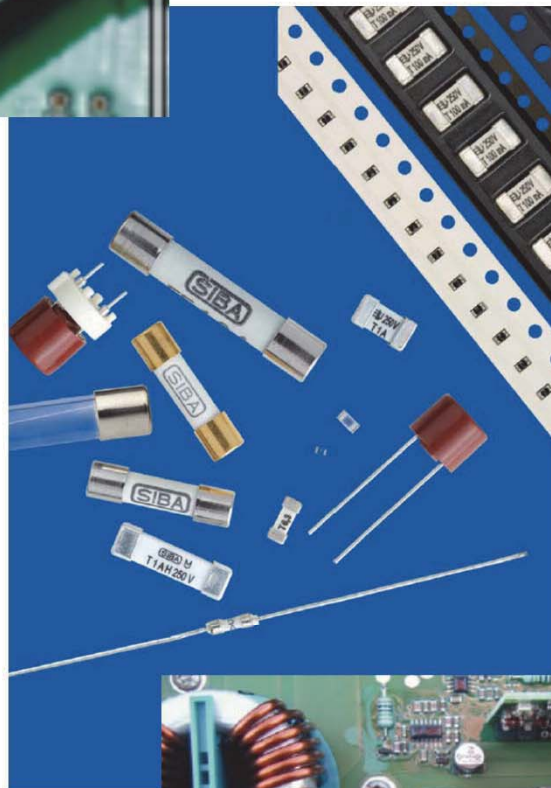
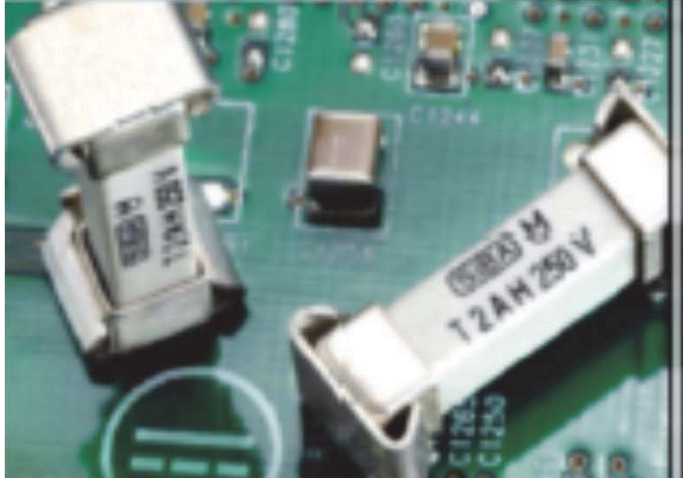

Miniature Fuses

General Information

	Page
General Product Information	618 - 620
Technical notes	621 - 624
Selection diagram	625

Sub-miniature Fuses

Chip 0402, 0603, 0805, 1206	626 - 629
2.6 x 6.1 mm (SMD)	630 - 631
4.5 x 8 mm (SMD)	632 - 634
4.5 x 16 mm (SMD)	635 - 637
8.4 x 7.6mm	638 - 642

G-Fuse Links

5 x 20 mm	643 - 657
10x 51 mm	658
5 x 25 mm	659 - 662
5 x L mm	663
5 x 30 mm	664
6.3 x 32 mm	665 - 674
8 x 40 mm	675
8 x 50 mm / 8 x 85 mm	676
8 x 120 mm / 8 x 150 mm	677
High voltage fuses	678

G-Fuse Holders and Fuse Bases

678 - 687



General Product Information

Article Number	Page	RoHS	Dimensions [mm]	Rated Voltage	Charac- teristics	Rated Breaking Current	Standard or Description
151000	626	◆	1.00 x 0.5	32V _{DC}	FF	50A	UL 248-14
152000	627	◆	1.55 x 0.85	32V _{DC}	FF	50A	UL 248-14, IEC 60127- 4
153000	628	◆	2.00 x 1.25	32V _{DC}	FF	50A	UL 248-14, IEC 60127- 4
154000	629	◆	3.20 x 1.6	63V _{DC}	FF	50A	UL 248-14, IEC 60127- 4
157000	630	◆	2.60 x 6.1	125V _{AC/DC}	F	50A _{AC/DC}	UL 248-14, CSA C22.s No 248.14
158000	631	◆		125V _{AC/DC}	T	50A _{AC/DC}	UL 248-14, CSA C22.s No 248.14
160000	632	◆	4.5 x 8.0	250V _{AC}	T	100A	IEC 60127
160500	633	◆	4.5 x 8.0	250V _{AC}	T	100A	IEC 60127
161000	634	◆	4.5 x 8.0	250V _{AC}	F	100A	IEC 60127-4
160016	635	◆	4.5 x 16	305V _{AC}	T	1.5kA	UL 248-14, IEC 60127-4/2
160516	636	◆	4.5 x 16	305V _{AC}	T	1.5kA	UL 248-14, IEC 60127-4/2
163016	637	◆	4.5 x 16	250V _{AC}	TT	135A	IEC 60127-4
164000	638	◆	8.4 x 7.6	250V _{AC}	F	(35A / 10xI _{Rat})	IEC 60127-3/3, EN 60127-3/3, VDE 0820-3/3
164050							
164500	639	◆	8.4 x 7.6	250V _{AC}	F	50A	UL 248-14, CSA C22.s No 248.14
164550							
165000	640	◆	8.4 x 7.6	250V _{AC}	M	(35A / 10xI _{Rat})	IEC 60127-3
165050							
166000	641	◆	8.4 x 7.6	250V _{AC}	T	(35A / 10xI _{Rat})	IEC 60127-3/4, EN 60127-3/4, VDE 0820-3/4
166050							
166500	642	◆	8.4 x 7.6	250V _{AC}	T	50A	UL 248-14, CSA C22.s No 248.14
166550							
7000140	643	◆	5 x 20	250V _{AC}	FF	200kA/1.5kA	Special type
7000740	644	◆	5 x 20	400V _{AC}	FF	10kA/200kA	Special type
7018040	645	◆	5 x 20	660V _{AC}	aR(FF)	100kA _{AC/DC}	Special type
179020	646	◆	5 x 20	250V _{AC}	F	(35A / 10xI _{Rat})	IEC 60127-2/2, EN 60127-2/2, VDE 0820-2/2
179021	647	◆	5 x 20	250V _{AC}	F	1.5kA/1kA	IEC 60127-2/1, EN 60127-2/1, VDE 0820-2/1
171100	648	◆	5 x 20	250V _{AC}	F	1kA/300A	DIN 41571-1
172000	649	◆	5 x 20	250V _{AC}	M	80A	DIN 41571-2
172100						1kA/300A	
172200	650	◆	5 x 20	250V _{AC}	M	1.5kA	DIN 41571-2
179120	651	◆	5 x 20	250V _{AC}	T	(35A / 10xI _{Rat})	IEC 60127-2/3, EN 60127-2/3, VDE 0820-2/3
179150	652	◆	5 x 20	250V _{AC}	T	150A	IEC 60127-2/6, EN 60127-2/6, VDE 0820-2/6
179200	653	◆	5 x 20	250V _{AC} /300V _{DC}	T	1.5kA _{AC/DC}	IEC 60127-2/6, EN 60127-2/6, VDE 0820-2/6
179200SMD	654	◆	5 x 20	250V _{AC}	T	1.5kA	IEC 60127-2/5, EN 60127-2/5, VDE 0820-2/5
173100	655	◆	5 x 20	250V _{AC}	T	300A	DIN 41571-3
179500	656	◆	5 x 20	250V _{AC}	T/D	35A/100A	UL 248-14, CSA C22.s No 248.14
190000	657	◆	5 x 20	250V _{AC}	TT	(35A / 10xI _{Rat})	Special type
7001908	658	◆	10 x 51	60V _{AC}		1.5kA	DIN 41572
171525	659	◆	5 x 25	250V _{AC}	F	50A/80A	Special type
172525					M		
171526	660	◆	5 x 25	250V _{AC}	F	1.5kA	DIN 41576-1
172526	661	◆	5 x 25	250V _{AC}	M	80A/1.5kA	DIN 41576-2
7008913	662	◆	5 x 25	450V _{AC} /250V _{DC}	F	70kA _{AC} /10kA _{DC}	Lloyds approved
7001607	663	◆	5 x 25	250V _{AC}	M	80A/1.5kA	DIN 41577T,2
7001707			5 x 25				
7001407			5 x 20				
7001205			5 x 20				
171530	664	◆	5 x 30	500V _{AC}	F	50A/80A	Special type
172530					M		
7012540	665	◆	6.3 x 32	700V _{AC} /500V _{AC}	FF	50kA/20kA	Special type
7017240	666	◆	6.3 x 32	1000V _{AC/DC}	aR(FF)	30kA _{AC/DC}	Short circuit protection only
7006584	667	◆	6.3 x 32	400V _{AC}	gRL	120kA	IEC 60269-4, VDE 0636 Teil 4

SIBA LLC

29 Fairfield Place

West Caldwell, New Jersey 07006

Phone 1-973-575-7422

Fax 1-973-575-5858

618

portal: www.siballc.net
e-mail: info@sibafuse.com

GSS



General Product Information

Article Number	Page	RoHS	Dimensions [mm]	Rated Voltage	Charac- teristics	Rated Breaking Current	Standard or Description
189000	668		6.3 x 32	250V _{AC}	F	(35A / 10xI _{Rat})	IEC 60269-2/4
189020	669		6.3 x 32	500V _{AC} /440V _{DC}	F	50kA/1.5kA	Special type
7009463	670		6.3 x 32	600V _{AC}	F	50kA	Special type
189100	671		6.3 x 32	250V _{AC}	T	(35A / 10xI _{Rat})	Special type
189140	672		6.3 x 32	500V _{AC} - 250V _{AC}	T	1.5kA/10kA	Special type
189500	673		6.3 x 32	250V _{AC} /125V _{AC}	T/D	100A/10kA	
7006526	674		6.3 x 32	400V _{DC}	gPV	30kA	Following IEC 60269-4
183000	675		8 x 40	500V _{AC}	M/F	80A/1.5kA	DIN 41686
184000	676		8 x 50	1.2kV _{AC}	M/F	35A	DIN 41570
7103401			8 x 50	1.2kV _{AC}	-	-	Fuse base
185000			8 x 85	3kV _{AC}	M/F	35A	DIN 41569
7103701			8 x 85	3kV _{AC}	-	-	Fuse base
186000	677		8 x 120	6kV _{AC}	M/F		DIN 41683
7104001			8 x 120	6kV _{AC}	-	-	Fuse base
187000			8 x 150	10kV _{AC}	M/F	35A	DIN 41684
7104301			8 x 150	10kV _{AC}	-	-	Fuse base
7011509	678		10 x 85	3kV _{AC}	F	150A	Company standard
7011527			10 x 85	1.5kV _{AC} /1kV _{DC}	T	10kA	Company standard
7011552			10 x 85	1.5kV _{AC} /1kV _{DC}	F	1.5kA _{AC} / 300A _{DC}	Company standard
7012927			11 x 79	1kV _{AC}	T	15kA	Company standard
7012952			11 x 79	1kV _{AC}	F	15kA	Company standard
7017182			10 x 85	1kV _{AC}	aM	25kA	Company standard
7002924			12 x 100	3kV _{AC}	F	300A	Company standard
7002927			12 x 100	3kV _{AC}	T	300A	Company standard
7003024			12 x 150	6kV _{AC}	F	300A	Company standard
7003124			12 x 200	10kV _{AC}	F	300A	Company standard

SIBA LLC











Phone 1-973-575-7422
Fax 1-973-575-5858

29 Fairfield Place
West Caldwell, New Jersey 07006

portal: www.siballc.net
e-mail: info@sibafuse.com



General Product Information

Article Number	Page	RoHS	Dimensions [mm]	Rated Voltage	Rated Current	Description		
7103702	678		10 x 85	3kV _{AC}	6.3A	Fuse holder, 4W		
7102901			12 x 100	3kV _{AC}	6.3A	Fuse base, 4W		
7103001			12 x 150	6kV _{AC}	4A	Fuse base, 4W		
7103101			12 x 200	10kV _{AC}	2A	Fuse base, 4W		
166602	679		8.4 x 7.6	250V _{AC}	6.3A	Fuse base PCB for 8.4 x7.6 subminiature fuse		
199073			Ø 5mm	-	6.3A	Fuse clips PCB for Ø 5mm		
199207				-	6.3A	Fuse clips PCB for Ø 5mm		
199429			Ø 6.3mm	-	10A	Fuse clips PCB for Ø 6.3mm		
199487				-	10A	Fuse clips PCB for Ø 6.3mm		
199011			5 x 20		250V _{AC} /300V _{DC}	6.3A	Fuse base SMD	
199012						-	Fuse base cover	
199015			680		5 x 20	250V _{AC}	6.3A	Fuse base PCB
199015A						-	Fuse base cover	
199016					5 x 20	250V _{AC}	6.3A	Fuse base PCB
199018	-	Fuse base cover						
199019	681		5 x 20	250V _{AC}	6.3A	Fuse base PCB		
199060			5 x 20	250V _{AC}	6.3A	Fuse base PCB		
199030			5 x 20	250V _{AC}	6.3A	Fuse holder panel mount, screw cap, 2.8mm plug or solder		
199035			5 x 20	250V _{AC}	6.3A	Fuse holder panel mount, screw cap, 2.8mm plug or solder		
199040			5 x 20	250V _{AC}	6.3A	Fuse holder panel mount, screw cap, 2.8mm plug or solder		
199045			5 x 20	250V _{AC}	6.3A	Fuse holder PCB vertical, bayonet cap		
199050			5 x 20	250V _{AC}	6.3A	Fuse holder PCB horizontal, bayonet cap		
199055			5 x 20	250V _{AC}	6.3A	Fuse holder panel mount, bayonet cap, solder		
199070			5 x 20	250V _{AC}	6.3A	Fuse holder panel mount, bayonet cap, 4.8mm plug or solder		
199080			682		5 x 20	250V _{AC}	6.3A VDE/10A UL	Fuse holder inline
199090	5x20/6.3x32	250V _{AC}			6.3A	Fuse holder panel mount, bayonet cap, solder		
199511	683		5x20/6.3x32	250V _{AC}	10A VDE/16A UL	Fuse base SMD		
199537			5x20/6.3x32	500V _{AC} /250V _{AC}	10A VDE/16A UL	Fuse base PCB		
199530			684		6.3x32	500V _{AC} /250V _{AC}	10A VDE/20A UL	Fuse holder panel mount, w/o cap, 6.3mm plug or solder
199531	500V _{AC} /250V _{AC}	10A VDE/20A UL				Fuse carrier bayonet cap		
199550	6.3x32	500V _{AC} /250V _{AC}			16A VDE/30A UL	Fuse holder PCB mount, w/o cap		
199552		500V _{AC} /250V _{AC}			16A VDE/30A UL	Fuse carrier screw cap for fuse holder		
199555	685		6.3x32	500V _{AC} /250V _{AC}	16A VDE/30A UL	Fuse holder panel mount, w/o cap, 6.3mm plug		
199552				500V _{AC} /250V _{AC}	16A VDE/30A UL	Fuse carrier screw cap for fuse holder		
7100127			5x20	250V _{AC}	10A VDE/16A UL	Fuse holder PCB mount horizontal w/ bayonet carrier		
7100128				250V _{AC}	10A VDE/16A UL	Fuse holder PCB mount vertical w/ bayonet carrier		
7100129				250V _{AC}	10A VDE/16A UL	Fuse holder panel mount w/ bayonet carrier, solder		
204000	686		Ø 5mm		6.3A max	Press on lead end cap PCB, lead Ø 0.65mm		
204001					10A max	Press on lead end cap PCB, lead Ø 0.8mm		
204002					16A max	Press on lead end cap PCB, lead Ø 1.0mm		
204100				Ø 6.3mm		12.5A max	Press on lead end cap PCB, lead Ø 0.8mm	
204101						20A max	Press on lead end cap PCB, lead Ø 1.0mm	
7100114	687		5x20/6.3x32	250V _{AC}	10A VDE/16A UL	Fuse holder PCB horizontal mount w/ bayonet		
7100116			5x20/6.3x32	250V _{AC}	10A VDE/16A UL	Fuse holder PCB vertical mount w/o bayonet		
7100123			5x20/6.3x32	250V _{AC}	10A VDE/10A UL	Fuse holder panel mount w/ out carrier, solder		
7100124			5x20/6.3x32	250V _{AC}	10A VDE/20A UL	Fuse holder panel mount w/o bayonet carrier, solder		
7200108			5x20			Fuse carrier bayonet for 5x20		
7200109			6.3x32			Fuse carrier bayonet for 6.3x32		

Technical Notes

1 Introduction

Miniature fuses are automatic switchgears that protect electrical plants, appliances and modules from inadmissibly high current loads. They have various applications. Miniature fuses are used in consumer electronics for safeguarding power supplies and power output amplifiers. They are often used in industrial applications as primary fuses, where in the event of a fault they separate the defective module from the voltage supply in order to forestall any greater damage.

Fuse-links for direct mounting on printed circuit boards are used among other things for the secondary current supply in low power devices. In the event of a fault they serve to protect components and PCB traces that might be destroyed by excessive current loads.

2 Designs

The traditional miniature fuse is cylindrical in shape, with a diameter of 5mm and a length of 20mm. There is also a design used internationally which has the dimensions 6.3 x 32mm. Depending on their rating, these fuses, whose characteristics might be very quick acting to long time-lag, can switch off short circuit currents of up to several kilo amperes at mains voltages of up to 1000V.

Sub-miniature fuses (KS) are used for through hole assembly on printed circuit boards. Whether their characteristics are quick acting or time-lag, these fuses with a rated voltage of 250V are used in primary circuits for protecting transformer mains and in secondary circuits for selective protection of the modules.

SMD fuses at rated voltages of up to 250V are available for surface mounting on printed circuit boards. Their applications are similar to those of the sub-miniature fuses (KS) described above. As regards their breaking performance, they are also designed with the special requirements of the telecom industry in mind.

3 Terminology

Miniature fuses consist of the fuse-link and the fuse holder. The fuse link contains the fuse-element and must, after the latter has melted, be replaced by a new fuse-link. The fuse-element can continuously carry the rated current under given conditions. When the rated current has been exceeded, the fuse-element melts above a value prescribed by the standards and the electrical circuit is broken. The duration of the melting process is prescribed in the relevant standards.

The fuse-link is inserted into a fuse-holder. The latter consists of the fuse base (mount) and the (screw or bayonet) fuse carrier. The fuse base is firmly mounted in the device to be protected and provides the electrical connection. The fuse carrier receives the fuse-link, allowing easy replacement. Open fuse holders and clips are often used besides such 'enclosed' fuse holders.

3.1 Rated voltage (nominal voltage) U_{rat}

The rated voltage of a fuse link is given as the r.m.s. value of a sinusoidal alternating voltage at 50 Hz. All the test conditions are laid down in accordance with it. The voltage U_b driving the short circuit current must not be greater than the rated voltage.

$$U_{rat} \geq U_b$$

Operation at direct voltage is possible if the rated voltage is reduced; we will be glad to advise you on this matter if you provide us with the maximum fault current and the time constants of the fault current circuit.

3.2 Rated Current I_n

The rated current given is the r.m.s. value. Under prescribed conditions, the fuse-link can operate permanently at the rated current level. Ambient conditions, cyclic currents and special assembly conditions can lead to a de-rating of the rated current. The I_b operating current must not be greater than the rated current during normal operation.

$$I_n \geq I_b$$

3.3 Rated Breaking Capacity I_1 at U_{rat}

The rated breaking capacity characterizes the maximum current I_1 that the fuse-link can properly switch off at the rated voltage. In certain applications it may be necessary to reduce the expected short-circuit current by means of additional impedances in the electrical circuit.

$$I_1 \geq I_p$$

3.4 Voltage Drop ΔU

The voltage drop is determined with the fuse-link in operation at its rated current and at an ambient temperature of 23°C.

3.5 Pre-arcing integral I^2t_s

The pre-arcing integral is calculated by integrating the square of the current over the pre-arcing time. The value indicates the electrical load that leads to the melting of the fuse-element. The value for the pre-arcing integral is determined at a test current of $10 I_{rat}$ given and is as a typical value.

3.6 Operating integral I^2t_A

The operating integral is calculated by integrating the square of the current over the total operating time of the fuse link. The value is a measure of the load on the downstream components during breaking operation of the fuse link in the event of a short circuit.

3.7 Power dissipation P_V

The Power dissipation of a fuse link is calculated by multiplying the conventional nonfusing current I_{nf} by the voltage drop ΔU determined at this load after an hour.

4 Structure of miniature Fuse-Links

4.1 The glass tube

If the maximum expected short circuit current (prospective current I_p) is not greater than 35 A or max. $10 I_{rat}$, then a miniature fuse link with an unfilled glass tube is used. This fuse-link has the advantage of a relatively low voltage drop.

4.2 The reinforced glass tube

Miniature fuse-links with reinforced unfilled glass tubes can switch off prospective currents of up to 150 A at the rated voltage.

4.3 The filled glass tube

Prospective currents of up to 1 000 A can be switched off at the rated voltage by a combination of quartz sand filling as extinguishing filler and reinforcement of the glass tube.

4.4 The filled ceramic tube

A further increase in the rated breaking capacity up to a prospective current of several kA is achieved by the use of ceramic tubes filled with quartz sand.

4.5 The terminal caps

A copper alloy is usually used as working material for the terminal caps. The caps are plated by means of a special surface treatment to provide better electrical and thermal contact, as well as for protection against corrosion.

5 Standards

Besides several specific national standards, the principal standard applied worldwide is IEC 60127. It is divided into one general part, parts dealing with the individual fuse designs, one part for fuse holders, one specification for quality confirmation as well as one user's manual. The German-language equivalent of this International Standard is VDE 0820.

In the North American countries, the reference standard for miniature fuses is UL 248. Special care is required as in converting the rated currents of IEC 60127 into those according to UL 248 (see figure 1).

6 Characteristics

The characteristic is an expression for the time-current performance of the fuse-links.

FF	Very quick acting	Short circuit protection for semiconductor components (diodes, thyristors, triacs, transistors, MCT, etc.)
gRL	Very quick acting	Full range protection of semiconductors and their supply lines
gPV		For protection of photovoltaic systems
F	Quick acting	Protection against high overload and short circuit currents, fuses are used in electrical circuit without inrush current pulse, or as mains fuses
M	Medium time lag	Used primarily at low operating voltages, if no high inrush currents have to be taken into account.
T	Time lag	For high inrush currents have slow decaying transients(e.g. transformers).
TT	Long time lag	For very high and long lasting inrush currents(e.g. motors)

7 Applications

7.1 Different definitions of the Rated Currents in the International Standards

In principle, two different ratings of the continuous current must be taken into account, preventing direct conversion of the fuse links according to IEC 60127 and UL 248-14.

a) Continuous current rating according to IEC 60127.

$$I_n \geq I_b$$

b) Continuous current rating according to UL 248-14.

$$I_n \geq I_b / 0.7$$

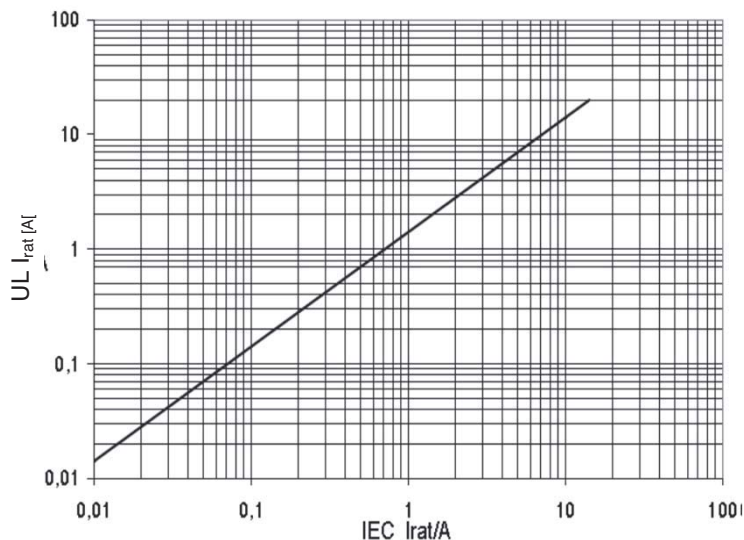

Figure 1 enables approximate conversion of rated current between UL and IEC standards

Figure 1

7.2 Operation at extra-Low-Voltage $U_b \ll U_{rat}$

Fuse-links can operate without difficulty at voltages below their rated voltage. The voltage drop of the fuse-links (internal resistance) must be taken into consideration, particularly at very low rated currents.

7.3 Operation at raised ambient temperatures

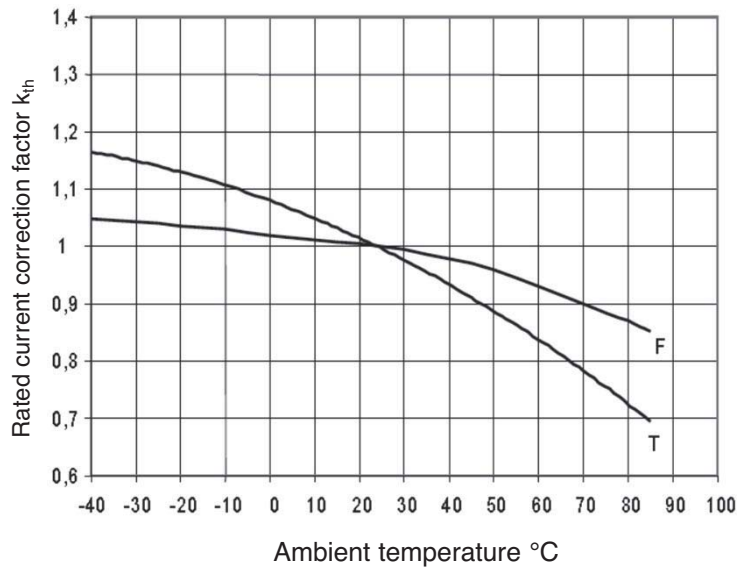

The shift in the rated current at various ambient temperatures can be determined with reference to Figure 2.

7.4 Pulse loads

If pulse loads arise in an electrical circuit to be protected, then that must be taken into consideration when assigning a fuse link, particularly the latter's pre-arcing integral I^2t s. Reduction factors can be provided on the basis of extensive series of in house tests relating to pulse amplitude, pulse duration and frequency of occurrence.

7.5 Protection of semiconductor components

When protecting power electronics components, the I^2t value of the fuse-link is adjusted to the energy pulse (or I^2t value) of the component to be protected.

7.6 Power acceptance of the miniature Fuse Holder

The maximum power acceptance of the fuse holder must not be exceeded by the Power dissipation of the fuse link selected. Contact resistances and assembly conditions shall additionally be taken into account here.

8 Safety through Quality

In order to ensure compliance with the quality requirements, SIBA practices the documented quality management system (QM system) on the basis of the International Standard DIN EN ISO 9001. The environmental management system according to DIN EN ISO 14001 regulates the planning, implementation and supervision of environmental protection in the company.

9 Selection diagram

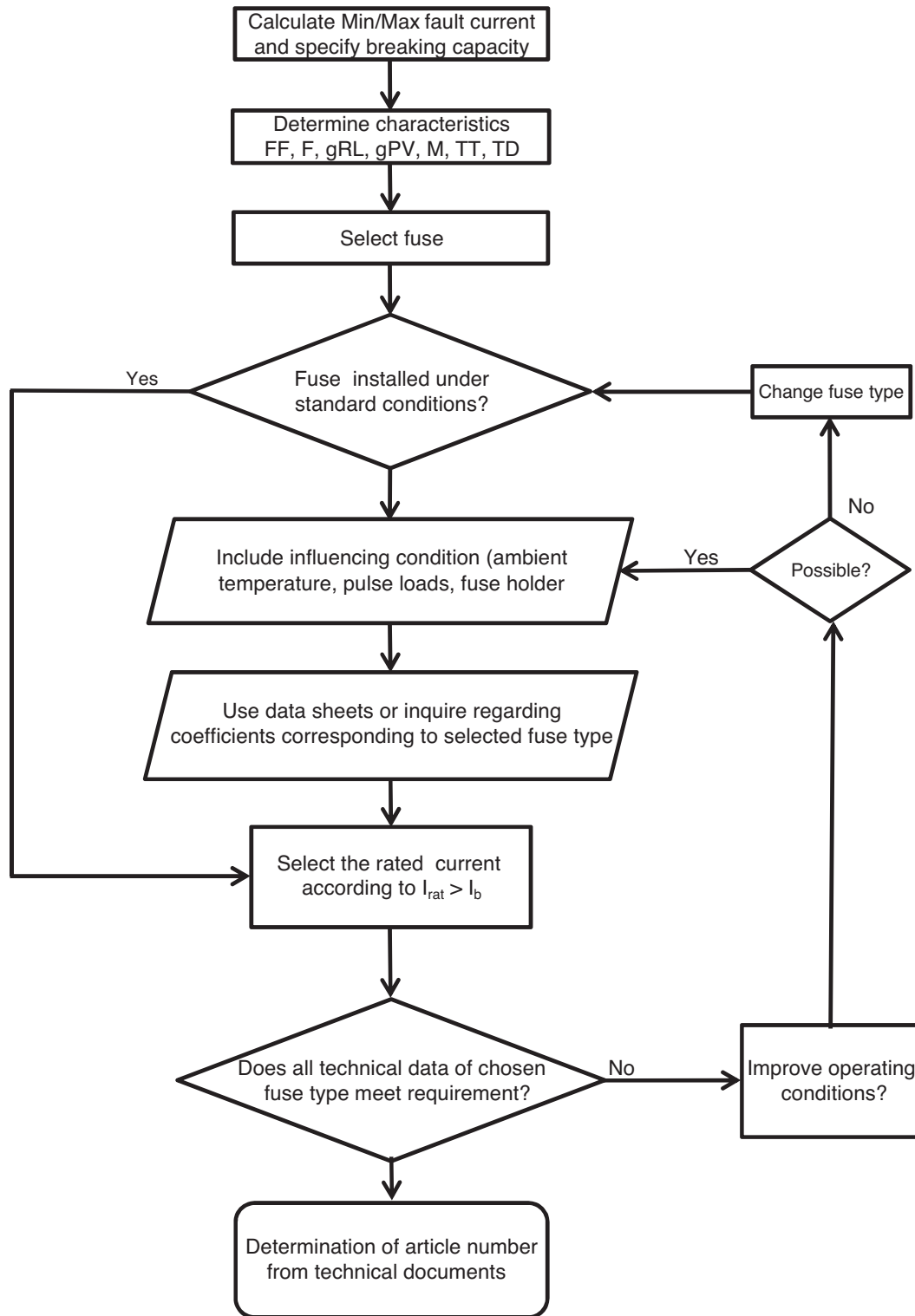

GSMC



E167295



Rated Voltage

[Un]
32V_{DC}

Rated Breaking Test

Voltage Capacity
32V_{DC} 50A_{DC}

Class

FF

Standard(s)

UL 248-14



0402(1mmx0.5mm) - Ceramic substrate - printed fuse element

Rated current I _n [A]	Article Number	UL rec	Rated breaking current [A]	Voltage drop [mV]	Cold resistance [mΩ]	Pre-arcing i ² t @ 10I _n [A ² s]	Approvals	Marking
0.500	151000.0.500	✓	50A @ 32V _{DC}	420	640	0.0009		
0.630	151000.0.630	✓	50A @ 32V _{DC}	331	400	0.0014		
0.750	151000.0.750	✓	50A @ 32V _{DC}	275	280	0.0020		
0.800	151000.0.800	✓	50A @ 32V _{DC}	231	220	0.0023		
1	151000.1	✓	50A @ 32V _{DC}	184	140	0.0028		
1.25	151000.1.25	✓	50A @ 32V _{DC}	159	97	0.0039		
1.5	151000.1.5	✓	50A @ 32V _{DC}	146	74	0.0059		
1.6	151000.1.6	✓	50A @ 32V _{DC}	136	65	0.0065		
1.75	151000.1.75	✓	50A @ 32V _{DC}	124	54	0.0077		
2	151000.2	✓	50A @ 32V _{DC}	115	44	0.0101		
2.5	151000.2.5		50A @ 32V _{DC}	107	33	0.0157		
3	151000.3		50A @ 32V _{DC}	95	24	0.0227		
3.15	151000.3.15		50A @ 32V _{DC}	90	22	0.0250		

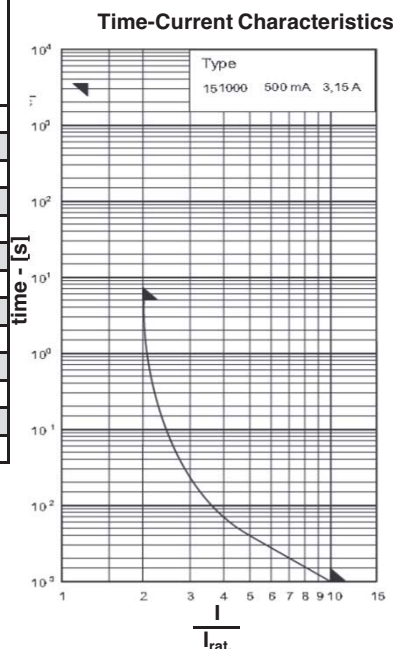

Tape reel ordering, add following suffix to article number

- GT-1k (1 000 pieces on tape reel)
- GT-5k (5 000 pieces on tape reel)
- GT-10k (10 000 pieces on tape reel)
- e.g. 151000.0.750GT-1k

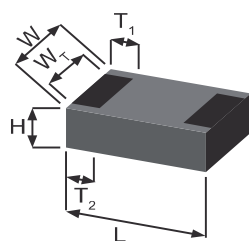

Dimensions	[mm]
H	0.32 ± 0.05
L	1.0 ± 0.05
W	0.5 ± 0.05
W _T	> 75% of W
T ₁	0.2+0.1/-0.15
T ₂	0.2 ± 0.1

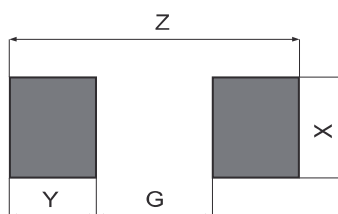

Reflow	Solder pad Dimensions [mm]	wave
0.25	G	
0.55	X	
0.6	Y	
1.45	Z	

Vibration IEC - 60068-2-6

Insulation resistance - IEC 60127-4

Rated current	Fusing Time Limits									
	1.25I _n		2I _n		2.75I _n		4I _n		10I _n	
	Min	Max	Min	Max	Min	Max	Min	Max	Min	Max
500mA - 3.15A	1h	—	—	1s	—	—	—	—	—	1ms

Resistance to soldering heat, 260°C, 10s, solder bath (to IEC 60068-2 -58) 260°C, 10s, reflow

SIBA LLC

29 Fairfield Place
West Caldwell, New Jersey 07006

Phone 1-973-575-7422
Fax 1-973-575-5858

portal: www.siballc.net
e-mail: info@sibafuse.com

GSMC



E167295



Rated Voltage

[Un]
32V_{DC}

Rated Breaking Test

Voltage 32V_{DC}
Capacity 50A_{DC}

Class

FF



Standard(s)

UL 248-14
IEC 60127-4

0603(1.55mmx0.85mm) - Ceramic substrate - printed fuse element

Rated current I_n [A]	Article Number	UL rec	Rated breaking current [A]	Voltage drop [mV]	Cold resistance [mΩ]	Pre-arcing I^2t @ 10I _n [A ² s]	Approvals V - VDE	Marking
0.500	152000.0.500	✓	50A @ 32V _{DC} ¹⁾	361	550	0.0009	V	F
0.630	152000.0.630	✓	50A @ 32V _{DC}	331	400	0.0014		CT
0.750	152000.0.750	✓	50A @ 32V _{DC}	258	262	0.0020		G
0.800	152000.0.800	✓	50A @ 32V _{DC}	249	237	0.0023		CV
1	152000.1	✓	50A @ 32V _{DC}	223	170	0.0028	V	H
1.25	152000.1.25	✓	50A @ 32V _{DC}	180	110	0.0039		J
1.5	152000.1.5	✓	50A @ 32V _{DC}	155	79	0.0059		K
1.6	152000.1.6	✓	50A @ 32V _{DC}	159	76	0.0065	V	EF
1.75	152000.1.75	✓	50A @ 32V _{DC}	138	60	0.0077		L
2	152000.2	✓	50A @ 32V _{DC}	150	57	0.0101	V	N
2.5	152000.2.5	✓	50A @ 32V _{DC}	151	37	0.0157		O
3	152000.3	✓	50A @ 32V _{DC}	126	32	0.0227		P
3.15	152000.3.15	✓	50A @ 32V _{DC}	120	29	0.0250	V	EL
3.5	152000.3.5	✓	50A @ 32V _{DC}	106	23	0.0308		R
4	152000.4	✓	50A @ 32V _{DC}	100	19	0.0403		S
5	152000.5		50A @ 32V _{DC}	85	13	0.2275		T

¹⁾ 50A @ 50V_{DC} with VDE approval

Tape reel ordering, add following suffix to article number

- GT-1k (1 000 pieces on tape reel)
- GT-5k (5 000 pieces on tape reel)
- GT-20k (20 000 pieces on tape reel)
- e.g. 152000.3.15GT-1k

Time-Current Characteristics

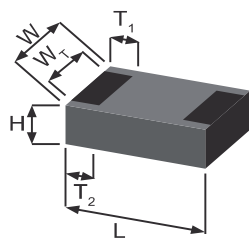
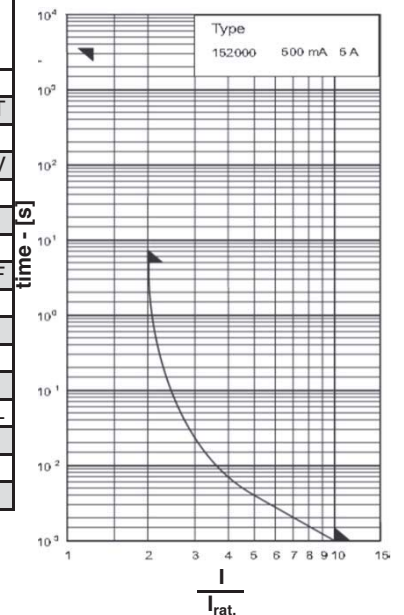

Dimensions	[mm]
H	0.45+01/-0.03
L	1.55 ± 0.05
W	0.85 ± 0.1
W _T	> 75% of W
T ₁	0.3+0.15/-0.2
T ₂	0.3+0.15/-0.2

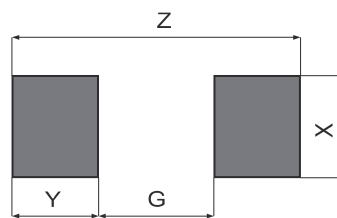

Reflow	Solder pad Dimensions [mm]	wave
0.5	G	0.5
0.95	X	1.1
0.95	Y	1.2
2.4	Z	2.9

Vibration IEC - 60068-2-6

Insulation resistance - IEC 60127-4

Rated current	Fusing Time Limits									
	1.25I _n		2I _n		2.75I _n		4I _n		10I _n	
	Min	Max	Min	Max	Min	Max	Min	Max	Min	Max
500mA - 5A	1h	—	—	5s	—	—	—	—	—	1ms

Resistance to soldering heat, 260°C, 10s, solder bath
(to IEC 60068-2 -58) 260°C, 10s, reflow



Rated Voltage
[Un]
32V_{DC}

Rated Breaking Test
Voltage Capacity
32V_{DC} 50A

Class
FF

Standard(s)
UL 248-14
IEC 60127-4



0805(2mmx1.25mm) - Ceramic substrate - printed fuse element

Rated current I_n [A]	Article Number	UL rec	Rated breaking current [A]	Voltage drop [mV]	Cold resistance [mΩ]	Pre-arcing i^2t @ 10I _n [A ² s]	Approvals V - VDE	Marking
0.500	153000.0.500	✓	50A @ 32V _{DC}	374	570	0.0009	V	F
0.630	153000.0.630	✓	50A @ 32V _{DC}	347	420	0.0014		CT
0.750	153000.0.750	✓	50A @ 32V _{DC}	280	285	0.0021		G
0.800	153000.0.800	✓	50A @ 32V _{DC}	262	250	0.0023		CV
1	153000.1	✓	50A @ 32V _{DC}	243	185	0.0028	V	H
1.25	153000.1.25	✓	50A @ 32V _{DC}	205	125	0.004		J
1.5	153000.1.5	✓	50A @ 32V _{DC}	171	87	0.0059		K
1.6	153000.1.6	✓	50A @ 32V _{DC}	164	78	0.0065	V	EF
1.75	153000.1.75	✓	50A @ 32V _{DC}	161	70	0.0077		L
2	153000.2	✓	50A @ 32V _{DC}	176	67	0.0101	V	N
2.5	153000.2.5	✓	50A @ 32V _{DC}	131	40	0.0157		O
3	153000.3	✓	50A @ 32V _{DC}	134	34	0.0227		P
3.15	153000.3.15	✓	50A @ 32V _{DC}	128	31	0.0250	V	EL
3.5	153000.3.5	✓	50A @ 32V _{DC}	119	26	0.0308		R
4	153000.4	✓	50A @ 32V _{DC}	105	20	0.0403		S
5	153000.5	✓	50A @ 32V _{DC}	98	15	0.2275		T

Time-Current Characteristics

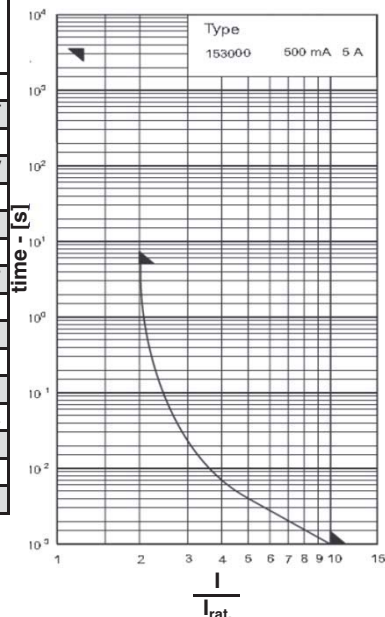

Tape reel ordering, add following suffix to article number

- GT-1k (1 000 pieces on tape reel)
- GT-5k (5 000 pieces on tape reel)
- GT-20k (20 000 pieces on tape reel)
- e.g. 153000.1.75GT-1k

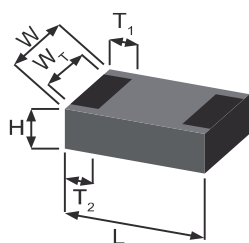

Dimensions	[mm]
H	0.45+01/-0.05
L	2.0 ± 0.1
W	1.25 ± 0.15
W _T	> 75% of W
T ₁	0.4+0.1/-0.2
T ₂	0.4+0.1/-0.2

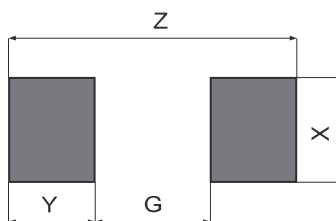

Reflow	Solder pad Dimensions [mm]	wave
0.65	G	0.65
1.4	X	1.5
1.1	Y	1.4
2.85	Z	3.45

Insulation resistance - IEC 60127-4

Vibration IEC - 60068-2-6

Rated current	Fusing Time Limits									
	1.25I _n		2I _n		2.75I _n		4I _n		10I _n	
	Min	Max	Min	Max	Min	Max	Min	Max	Min	Max
500mA - 5A	1h	—	—	5s	—	—	—	—	—	1ms

Resistance to soldering heat, 260°C, 10s, solder bath
(to IEC 60068-2 -58) 260°C, 10s, reflow

GSMC



E167295



Rated Voltage

[Un]

63V_{DC}



Rated Breaking Test

Voltage

125V_{AC}

Capacity

50A

Class

FF



Standard(s)

UL 248-14

IEC 60127-4

1206(3.2mmx1.6mm) - Ceramic substrate - printed fuse element

Rated current I _n [A]	Article Number	UL rec	Rated breaking current [A]	Voltage drop [mV]	Cold Pre-arcing resistance [mΩ]	I ² t @ 10I _n [A ² s]	Approvals V - VDE	Marking
0.250	154000.0.250	*		310	880	0.0001		
0.375	154000.0.375	*		260	470	0.0004		
0.500	154000.0.500	✓	50A @ 63V _{DC} ²	433	660	0.0009	V	F
0.630	154000.0.630	✓	50A @ 63V _{DC}	372	450	0.0014		CT
0.750	154000.0.750	✓	50A @ 63V _{DC}	325	330	0.0022		G
0.800	154000.0.800	✓	50A @ 63V _{DC}	273	260	0.0023		CV
1	154000.1	✓	50A @ 63V _{DC} ²	262	200	0.0028	V	H
1.25	154000.1.25	✓	50A @ 63V _{DC}	230	140	0.0041		J
1.5	154000.1.5	✓	50A @ 63V _{DC}	207	105	0.0059		K
1.6	154000.1.6	✓	50A @ 63V _{DC} ²	168	80	0.0066	V	EF
1.75	154000.1.75	✓	50A @ 63V _{DC}	174	76	0.0077		L
2	154000.2	✓	50A @ 63V _{DC} ²	181	69	0.0102	V	N
2.5	154000.2.5	✓	50A @ 63V _{DC}	161	49	0.0159		O
3	154000.3	✓	50A @ 63V _{DC}	173	44	0.0229		P
3.15	154000.3.15	✓	50A @ 63V _{DC} ²	153	37	0.0251	V	EL
3.5	154000.3.5	✓	50A @ 63V _{DC}	161	35	0.0310		R
4	154000.4	✓	50A @ 63V _{DC}	147	28	0.0404		S
5	154000.5		50A @ 63V _{DC}	131	20	0.2275		T
6.3	154000.6.3		50A @ 63V _{DC}	116	14	0.516		ET

* UL listed

¹⁾ 50A @ 63V_{DC}, 100A @ 125V_{AC}

²⁾ 50A @ 50V_{DC} with VDE approval

Time-Current Characteristics

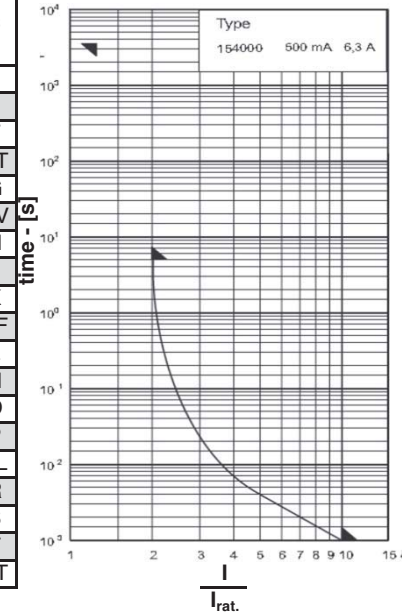

Tape reel ordering, add following suffix to article number

- GT-1k (1 000 pieces on tape reel)
- GT-5k (5 000 pieces on tape reel)
- GT-20k (20 000 pieces on tape reel)
- e.g. 154000.6.3GT-5k

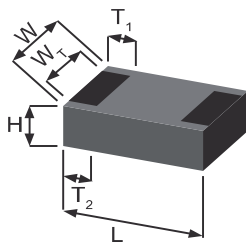

Dimensions	[mm]
H	0.55 ± 0.1
L	3.2+0.1/-0.2
W	1.6 ± 0.15
W _T	> 75% of W
T ₁	0.5 ± 0.25
T ₂	0.3 ± 0.25

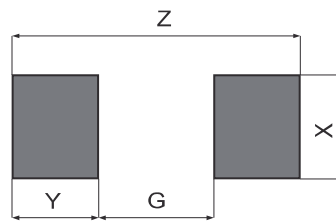

Reflow	Solder pad Dimensions [mm]	wave
1.5	G	1.5
1.75	X	1.9
1.25	Y	1.6
4.0	Z	4.7

Insulation resistance - IEC 60127-4

Vibration IEC - 60068-2-6

Rated current	Fusing Time Limits									
	1I _n		1.25I _n		2I _n		3I _n		10I _n	
	Min	Max	Min	Max	Min	Max	Min	Max	Min	Max
250mA - 375mA	1h	—	—	—	—	5s	—	200ms	—	—
500mA - 6.3A	—	—	1h	—	—	5s	—	—	—	1ms

Resistance to soldering heat, 260°C, 10s, solder bath (to IEC 60068-2 -58) 260°C, 10s, reflow

GSMB



E167295



Rated Voltage

[Un]
125/65V_{AC/DC}

Rated Breaking Test

Voltage Capacity
125V_{AC/DC}
65V_{AC/DC}
50A

Class

F



Standard(s)

UL 248-14
CSA C22.2 -
No 248.14

2.6mmx6.1mm - Ceramic body - contacts, brass - silver plated

Rated current I_n [A]	Article Number	UL rec	Rated breaking current [A]	Voltage drop [mV]	Cold resistance [mΩ]	Pre-arcing I^2t @ $10I_n$ [A ² s]	Approvals	Marking
0.062	157000.0.062	✓	50A @ 125V _{AC/DC}	600	5 500	0.00019		
0.080	157000.0.080	✓	50A @ 125V _{AC/DC}	550	4 050	0.00033		
0.100	157000.0.100	✓	50A @ 125V _{AC/DC}	350	2 000	0.0014		
0.125	157000.0.125	✓	50A @ 125V _{AC/DC}	240	1 500	0.0028		
0.160	157000.0.160	✓	50A @ 125V _{AC/DC}	350	1 400	0.0031		
0.200	157000.0.200	✓	50A @ 125V _{AC/DC}	250	800	0.0066		
0.250	157000.0.250	✓	50A @ 125V _{AC/DC}	230	600	0.011		
0.315	157000.0.315	✓	50A @ 125V _{AC/DC}	210	420	0.023		
0.375	157000.0.375	✓	50A @ 125V _{AC/DC}	180	300	0.043		
0.400	157000.0.400	✓	50A @ 125V _{AC/DC}	180	290	0.048		
0.500	157000.0.500	✓	50A @ 125V _{AC/DC}	180	230	0.073		
0.630	157000.0.630	✓	50A @ 125V _{AC/DC}	180	190	0.12		
0.750	157000.0.750	✓	50A @ 125V _{AC/DC}	170	160	0.18		
0.800	157000.0.800	✓	50A @ 125V _{AC/DC}	160	130	0.26		
1	157000.1	✓	50A @ 125V _{AC/DC}	150	100	0.45		
1.25	157000.1.25	✓	50A @ 125V _{AC/DC}	150	78	0.68		
1.5	157000.1.5	✓	50A @ 125V _{AC/DC}	150	63	0.85		
1.6	157000.1.6	✓	50A @ 125V _{AC/DC}	140	58	1.05		
2	157000.2	✓	50A @ 125V _{AC/DC}	100	37	0.57		
2.5	157000.2.5	✓	50A @ 125V _{AC/DC}	100	28	1.1		
3	157000.3	✓	50A @ 125V _{AC/DC}	100	23	1.5		
3.15	157000.3.15	✓	50A @ 125V _{AC/DC}	100	21	1.9		
3.5	157000.3.5	✓	50A @ 125V _{AC/DC}	100	19	2.5		
4	157000.4	✓	50A @ 125V _{AC/DC}	100	16	3.3		
5	157000.5	✓	50A @ 125V _{AC/DC}	90	12.5	6.2		
6.3	157000.6.3	✓	50A @ 125V _{AC/DC}	90	10	9.1		
7	157000.7	✓	50A @ 125V _{AC/DC}	90	8.6	11		
10	157000.10	✓	50A @ 65V _{AC/DC}	90	5.9	27		
12	157000.12	✓	50A @ 65V _{AC/DC}	90	4.9	45		
15	157000.15	✓	50A @ 65V _{AC/DC}	90	3.8	81		

Time-Current Characteristics

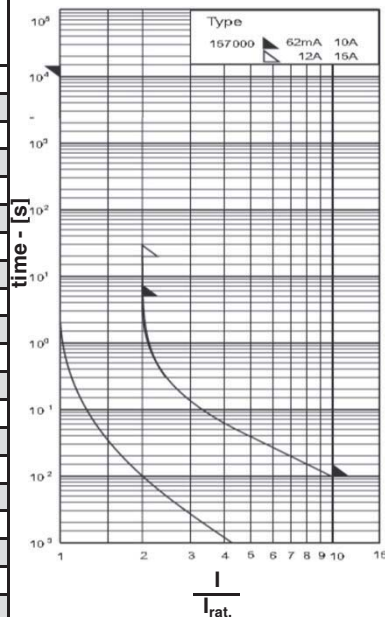

Tape reel ordering, add following suffix to article number
GT - (1 500 pieces on tape reel)
e.g. 157000.3.15GT

Dimensions [mm]

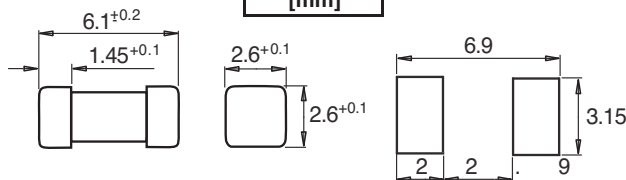

Recommended pad layout

Rated current	Fusing Time Limits									
	$1I_n$		$2I_n$		$2.75I_n$		$4I_n$		$10I_n$	
	Min	Max	Min	Max	Min	Max	Min	Max	Min	Max
62mA - 10A	4h	—	—	5s	—	—	—	—	—	10ms
12A - 15A	4h	—	—	20s	—	—	—	—	—	10ms

Resistance to soldering heat, 260°C, 10s, to IEC 60068

GSMB
 **RoHS**
 E167295
 2.6mmx6.1mm - Ceramic body - contacts, brass - silver plated

Rated Voltage
 [Un]
 125V_{AC/DC}

Rated Breaking Test
 Voltage Capacity
 125V_{AC/DC} 50A

Class
 T

Standard(s)
 UL 248-14
 CSA C22.s -
 No 248.14



Rated current I_n [A]	Article Number	UL rec	Rated breaking current [A]	Voltage drop [mV]	Cold resistance [mΩ]	Pre-arcing I^2t @ $10I_n$ [A ² s]	Approvals	Marking
0.250	158000.0.250	✓	50A @ 125V _{AC/DC}	280	900	0.08		
0.315	158000.0.315	✓	50A @ 125V _{AC/DC}	260	700	0.016		
0.375	158000.0.375	✓	50A @ 125V _{AC/DC}	230	500	0.035		
0.400	158000.0.400	✓	50A @ 125V _{AC/DC}	220	450	0.035		
0.500	158000.0.500	✓	50A @ 125V _{AC/DC}	200	300	1.0		
0.630	158000.0.630	✓	50A @ 125V _{AC/DC}	200	200	1.4		
0.750	158000.0.750	✓	50A @ 125V _{AC/DC}	190	170	1.5		
0.800	158000.0.800	✓	50A @ 125V _{AC/DC}	170	140	1.5		
1	158000.1	✓	50A @ 125V _{AC/DC}	150	120	4.0		
1.25	158000.1.25	✓	50A @ 125V _{AC/DC}	150	90	4.6		
1.5	158000.1.5	✓	50A @ 125V _{AC/DC}	130	60	4.8		
1.6	158000.1.6	✓	50A @ 125V _{AC/DC}	130	55	4.8		
2	158000.2	✓	50A @ 125V _{AC/DC}	120	45	8.6		
2.5	158000.2.5	✓	50A @ 125V _{AC/DC}	120	30	16		
3	158000.3	✓	50A @ 125V _{AC/DC}	110	23	24		
3.15	158000.3.15	✓	50A @ 125V _{AC/DC}	100	20	24		
3.5	158000.3.5	✓	50A @ 125V _{AC/DC}	100	18	38		
4	158000.4	✓	50A @ 125V _{AC/DC}	90	15	44		
5	158000.5	✓	50A @ 125V _{AC/DC}	90	11	77		
6.3	158000.6.3	✓	50A @ 125V _{AC/DC}	80	8	130		
7	158000.7	✓	50A @ 125V _{AC}	90	8	130		

¹⁾ 50A @ 125V_{AC} and 50A @ 65V_{DC} with UL recognition

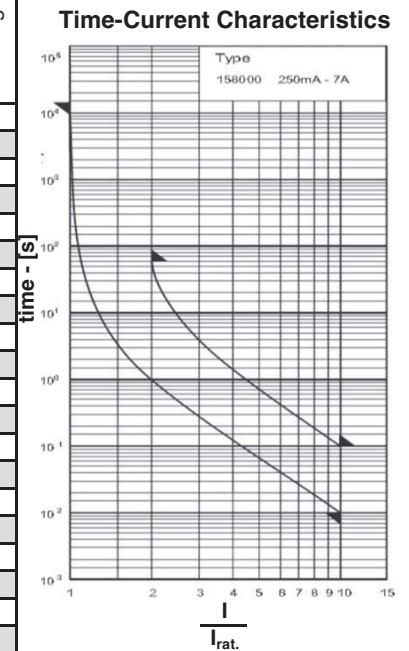

Tape reel ordering, add following suffix to article number
 GT - (1 500 pieces on tape reel)
 e.g. 158000.2.5GT



Dimensions
[mm]

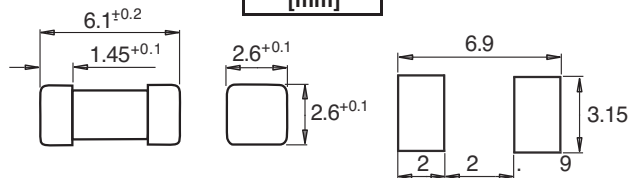

Recommended pad layout

Rated current	Fusing Time Limits									
	$1I_n$		$2I_n$		$2.75I_n$		$4I_n$		$10I_n$	
	Min	Max	Min	Max	Min	Max	Min	Max	Min	Max
250mA - 7A	4h	—	—	60s	—	—	—	—	10ms	100ms

Resistance to soldering heat, 260°C, 10s, to IEC 60068

GSMB
 US
 E167295



Rated Voltage
 [Un]
 250V_{AC}

Rated Breaking Test
 Voltage
 250V_{AC}
 Capacity
 100A

Class
 T

Standard(s)
 IEC 60127

4.5mmx8mm - Ceramic tube - contacts, brass - silver plated

Rated current I _n [A]	Article Number	UL rec	Rated breaking current [A]	Voltage drop [mV]	Power dissipation @ 1.5I _n [mW]	Pre-arcing i ² t @ 10I _n [A ² s]	Approvals	Marking
0.032	160000.0.032	✓	100A @ 250V _{AC}	1 150	125	0.014		
0.040	160000.0.040	✓	100A @ 250V _{AC}	860	150	0.013		
0.050	160000.0.050	✓	100A @ 250V _{AC}	800	155	0.013		
0.063	160000.0.063	✓	100A @ 250V _{AC}	580	160	0.020		
0.080	160000.0.080	✓	100A @ 250V _{AC}	480	165	0.035		
0.100	160000.0.100	✓	100A @ 250V _{AC}	350	170	0.06		
0.125	160000.0.125	✓	100A @ 250V _{AC}	300	180	0.12		
0.160	160000.0.160	✓	100A @ 250V _{AC}	280	190	0.21		
0.200	160000.0.200	✓	100A @ 250V _{AC}	260	200	0.32		
0.250	160000.0.250	✓	100A @ 250V _{AC}	240	220	0.5		
0.315	160000.0.315	✓	100A @ 250V _{AC}	220	250	0.8		
0.400	160000.0.400	✓	100A @ 250V _{AC}	200	280	1.1		
0.500	160000.0.500	✓	100A @ 250V _{AC}	190	310	1.8		
0.630	160000.0.630	✓	100A @ 250V _{AC}	180	360	3.2		
0.800	160000.0.800	✓	100A @ 250V _{AC}	160	430	5.2		
1	160000.1	✓	100A @ 250V _{AC}	140	500	6.8		
1.25	160000.1.25	✓	100A @ 250V _{AC}	130	600	12		
1.6	160000.1.6	✓	100A @ 250V _{AC}	120	730	22		
2	160000.2	✓	100A @ 250V _{AC}	100	870	30		
2.5	160000.2.5	✓	100A @ 250V _{AC}	100	1 000	46		
3.15	160000.3.15	✓	100A @ 250V _{AC}	100	1 200	80		
4	160000.4	✓	100A @ 250V _{AC}	100	1 400	130		
5	160000.5	✓	100A @ 250V _{AC}	100	1 700	130		

IEC 32mA - 250mA, 100A @ 125V_{DC}
 IEC 315mA - 5A, 100A @ 60V_{DC}

Time-Current Characteristics

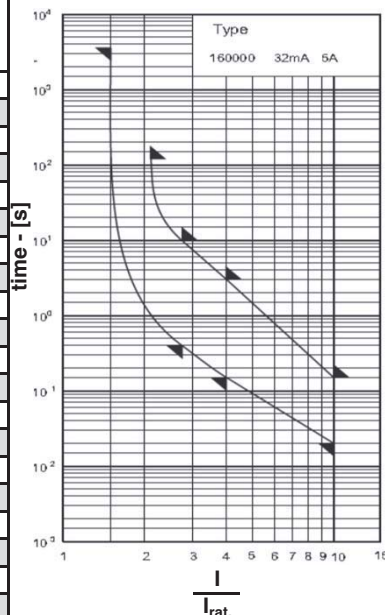

Tape reel ordering, add following suffix to article number
 GT - (1 500 pieces on tape reel)
 e.g. 160000.0.5GT



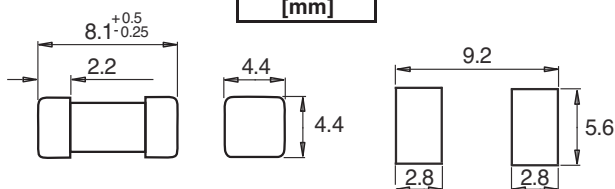

Dimensions
 [mm]



Recommended pad layout

Rated current	Fusing Time Limits									
	1.5I _n		2.1I _n		2.75I _n		4I _n		10I _n	
	Min	Max	Min	Max	Min	Max	Min	Max	Min	Max
32mA - 5A	1h	—	—	2m	400ms	10s	150ms	3s	20ms	150ms

Resistance to soldering heat, 260°C, 10s, solder bath
 (to IEC 60068-2 -58)

GSMB  **RoHS**  **Rated Voltage** [Un] **Rated Breaking Test** **Class** **Standard(s)**
250V_{AC} **250V_{AC}** **100A** **T** **IEC 60127**
 E167295
 4.5mmx8mm - Ceramic tube - fuse clip contacts bronze - tin plated

Rated current I_n [A]	Article Number	UL rec	Rated breaking current [A]	Voltage drop [mV]	Power dissipation @ 1.5 I_n [mW]	Pre-arcing I^2t @ 10 I_n [A ² s]	Approvals	Marking
0.032	160500.0.032	✓	100A @ 250V _{AC}	1 150	125	0.014		
0.040	160500.0.040	✓	100A @ 250V _{AC}	860	150	0.013		
0.050	160500.0.050	✓	100A @ 250V _{AC}	800	155	0.013		
0.063	160500.0.063	✓	100A @ 250V _{AC}	580	160	0.020		
0.080	160500.0.080	✓	100A @ 250V _{AC}	480	165	0.035		
0.100	160500.0.100	✓	100A @ 250V _{AC}	350	170	0.06		
0.125	160500.0.125	✓	100A @ 250V _{AC}	300	180	0.12		
0.160	160500.0.160	✓	100A @ 250V _{AC}	280	190	0.21		
0.200	160500.0.200	✓	100A @ 250V _{AC}	260	200	0.32		
0.250	160500.0.250	✓	100A @ 250V _{AC}	240	220	0.5		
0.315	160500.0.315	✓	100A @ 250V _{AC}	220	250	0.8		
0.400	160500.0.400	✓	100A @ 250V _{AC}	200	280	1.1		
0.500	160500.0.500	✓	100A @ 250V _{AC}	190	310	1.8		
0.630	160500.0.630	✓	100A @ 250V _{AC}	180	360	3.2		
0.800	160500.0.800	✓	100A @ 250V _{AC}	160	430	5.2		
1	160500.1	✓	100A @ 250V _{AC}	140	500	6.8		
1.25	160500.1.25	✓	100A @ 250V _{AC}	130	600	12		
1.6	160500.1.6	✓	100A @ 250V _{AC}	120	730	22		
2	160500.2	✓	100A @ 250V _{AC}	100	870	30		
2.5	160500.2.5	✓	100A @ 250V _{AC}	100	1 000	46		
3.15	160500.3.15	✓	100A @ 250V _{AC}	100	1 200	80		
4	160500.4	✓	100A @ 250V _{AC}	100	1 400	130		
5	160500.5	✓	100A @ 250V _{AC}	100	1 700	130		

IEC 32mA - 250mA, 100A @ 125V_{DC}
 IEC 315mA - 5A, 100A @ 60V_{DC}

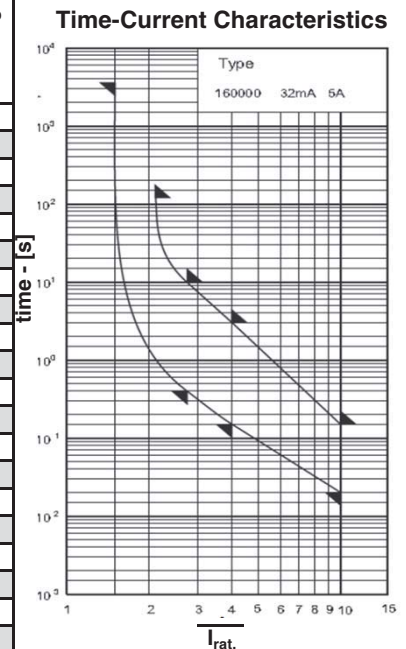

Tape reel ordering, add following suffix to article number
 GT - (800 pieces on tape reel)
 e.g. 160000.0.5GT

Dimensions
[mm]

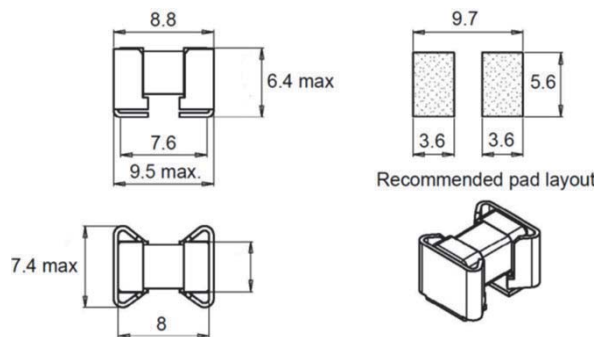

Rated current	Fusing Time Limits									
	1.5 I_n		2.1 I_n		2.75 I_n		4 I_n		10 I_n	
	Min	Max	Min	Max	Min	Max	Min	Max	Min	Max
32mA - 5A	1h	—	—	2m	400ms	10s	150ms	3s	20ms	150ms

Resistance to soldering heat, 260°C, 10s, solder bath
 (to IEC 60068-2 -58)

GSMB **Rated Voltage** **Rated Breaking Test** **Class** **Standard(s)**

[Un] **Voltage** **Capacity** **F** **IEC 60127-4**

250V_{AC} 250V_{AC} 100A

4.5mmx8mm - Ceramic tube w/ filler, contacts - brass - silver plated

Rated current I_n [A]	Article Number	Rated breaking current [A]	Voltage drop [mV]	Power dissipation @ 1.25 I_n [mW]	Pre-arcing I^2t [A ² s]	Approvals	Marking
0.500	161000.0.500	100A @ 250V _{AC}	200	300	0.076		
0.630	161000.0.630	100A @ 250V _{AC}	180	300	0.19		
0.800	161000.0.800	100A @ 250V _{AC}	160	300	0.38		
1	161000.1	100A @ 250V _{AC}	140	300	0.71		
1.25	161000.1.25	100A @ 250V _{AC}	140	400	0.94		
1.6	161000.1.6	100A @ 250V _{AC}	120	400	0.56		
2	161000.2	100A @ 250V _{AC}	110	500	1.1		
2.5	161000.2.5	100A @ 250V _{AC}	100	600	2.0		
3.15	161000.3.15	100A @ 250V _{AC}	100	700	3.2		
4m	161000.4	100A @ 250V _{AC}	100	900	5.0		
5	161000.5	100A @ 250V _{AC}	100	1 000	9.0		
6.3	161000.6.3	100A @ 250V _{AC}	100	1 400	13		

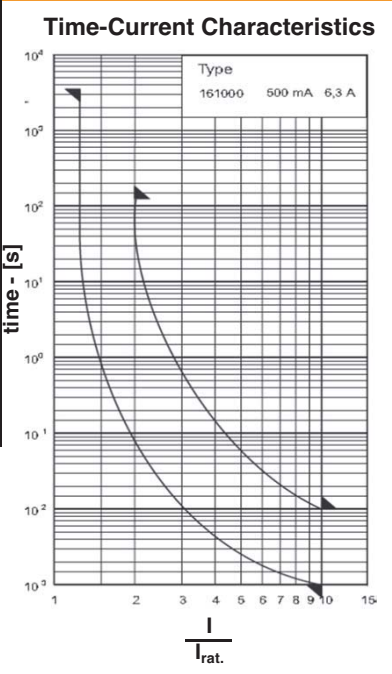

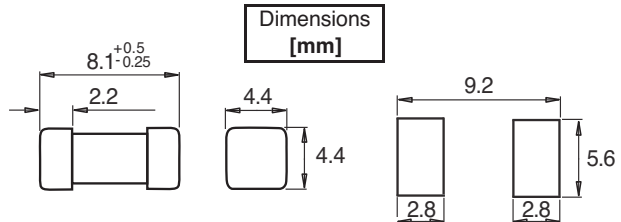

Tape reel ordering, add following suffix to article number
 GT - (1 500 pieces on tape reel)
 e.g. 161000.1.6GT



Recommended pad layout

Rated current	Fusing Time Limits									
	1.25 I_n		2 I_n		2.75 I_n		4 I_n		10 I_n	
	Min	Max	Min	Max	Min	Max	Min	Max	Min	Max
500mA - 6.3A	1h	—	—	2m	—	—	—	—	1ms	10ms

Resistance to soldering heat, 260°C, 10s, solder bath
 (to IEC 60068-2 -58)

GSMB   **Rated Voltage** [Un] **Rated Breaking Test** **Class** **Standard(s)**
CUL **US** **250V_{AC}** **Voltage** **Capacity** **T** **UL 248-14**
E167295 **100A** **IEC 60127-4/2**
4.5mmx16mm - Ceramic tube w/ filler, contacts - copper alloy - silver plated

Rated current I_n [A]	Article Number	UL rec	Rated breaking current [A]	Voltage drop [mV]	Power dissipation @ 1.25 I_n [mW]	Pre-arcing I^2t @ 10 I_n [A ² s]	Approvals S - Semko	Marking
0.050	160016.0.050	✓	1.5kA @ 305V _{AC}	2 600	260	0.010		
0.080	160016.0.080	✓	1.5kA @ 305V _{AC}	2 050	270	0.025	S	
0.100	160016.0.100	✓	1.5kA @ 305V _{AC}	1 750	290	0.030	S	
0.125	160016.0.125	✓	1.5kA @ 305V _{AC}	1 430	310	0.055	S	
0.160	160016.0.160	✓	1.5kA @ 305V _{AC}	1 220	340	0.065	S	
0.200	160016.0.200	✓	1.5kA @ 305V _{AC}	960	350	0.11	S	
0.250	160016.0.250	✓	1.5kA @ 305V _{AC}	840	360	0.19	S	
0.315	160016.0.315	✓	1.5kA @ 305V _{AC}	700	380	0.34	S	
0.400	160016.0.400	✓	1.5kA @ 305V _{AC}	570	400	0.54	S	
0.500	160016.0.500	✓	1.5kA @ 305V _{AC}	490	430	0.86	S	
0.630	160016.0.630	✓	1.5kA @ 305V _{AC}	410	460	1.5	S	
0.800	160016.0.800	✓	1.5kA @ 305V _{AC}	350	490	2.6	S	
1	160016.1	✓	1.5kA @ 305V _{AC}	380	640	4.5	S	
1.25	160016.1.25	✓	1.5kA @ 305V _{AC}	340	790	4.1	S	
1.6	160016.1.6	✓	1.5kA @ 305V _{AC}	330	970	6.2	S	
2	160016.2	✓	1.5kA @ 305V _{AC}	280	1 060	13	S	
2.5	160016.2.5	✓	1.5kA @ 305V _{AC}	240	1 120	21	S	
3.15	160016.3.15	✓	1.5kA @ 305V _{AC}	200	1 200	35	S	
4	160016.4	✓	1.5kA @ 305V _{AC}	160	1 250	49	S	
5	160016.5	✓	1.5kA @ 277V _{AC}	140	1 300	92	S	
6.3	160016.6.3	✓	1.5kA @ 277V _{AC}	120	1 370	170	S	
8	160016.8	✓	1.5kA @ 250V _{AC}	90	1 250	160	S	
10	160016.10	✓	1.5kA @ 250V _{AC}	80	1 500	280	S	

1) 1.5kA @ 250V_{DC}

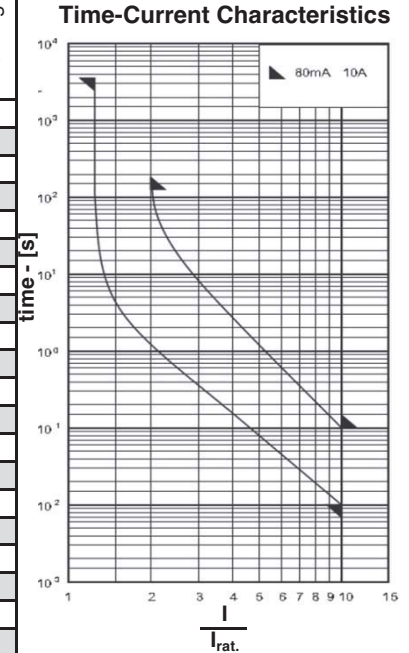

Tape reel ordering, add following suffix to article number
 GT - (1 500 pieces on tape reel)
 e.g. 160016.1.25GT



Dimensions [mm]

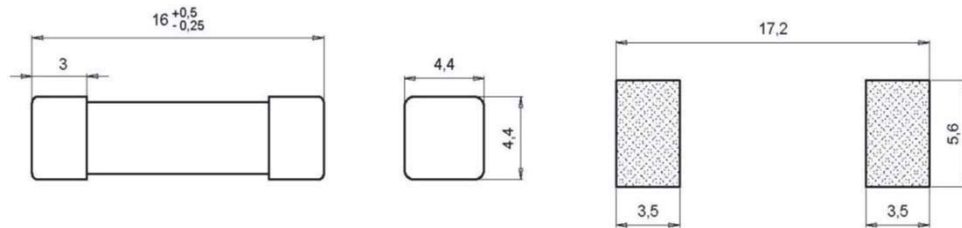

Recommended pad layout

Rated current	Fusing Time Limits									
	1.25 I_n		2 I_n		2.75 I_n		4 I_n		10 I_n	
	Min	Max	Min	Max	Min	Max	Min	Max	Min	Max
80mA - 10A	1h	—	2m	—	—	—	—	—	10ms	100ms

Resistance to soldering heat, 260°C, 10s, to IEC 60068

GSMB



E167295



Rated Voltage

[Un]
305V_{AC} - 250V_{AC}
250V_{DC}

Rated Breaking Test

Voltage Capacity
305V_{AC} - 250V_{AC} 1.5kA
250V_{DC} 1.5kA

Class

T

Standard(s)

UL 248-14
IEC 60127-4/2

4.5mmx16mm - Ceramic tube w/ filler, fuse clip contacts bronze - tin plated

Rated current I_n [A]	Article Number	UL rec	Rated breaking current [A]	Voltage drop [mV]	Power dissipation @ 1.25 I_n [mW]	Pre-arcing I^2t @ 10 I_n [A ² s]	Approvals S - Semko	Marking
0.050	160516.0.050	✓	1.5kA @ 305V _{AC} ¹⁾	2 600	260	0.010		
0.080	160516.0.080	✓	1.5kA @ 305V _{AC} ¹⁾	2 050	270	0.025	S	
0.100	160516.0.100	✓	1.5kA @ 305V _{AC} ¹⁾	1 750	290	0.030	S	
0.125	160516.0.125	✓	1.5kA @ 305V _{AC} ¹⁾	1 430	310	0.055	S	
0.160	160516.0.160	✓	1.5kA @ 305V _{AC} ¹⁾	1 220	340	0.065	S	
0.200	160516.0.200	✓	1.5kA @ 305V _{AC} ¹⁾	960	350	0.11	S	
0.250	160516.0.250	✓	1.5kA @ 305V _{AC} ¹⁾	840	360	0.19	S	
0.315	160516.0.315	✓	1.5kA @ 305V _{AC} ¹⁾	700	380	0.34	S	
0.400	160516.0.400	✓	1.5kA @ 305V _{AC} ¹⁾	570	400	0.54	S	
0.500	160516.0.500	✓	1.5kA @ 305V _{AC} ¹⁾	490	430	0.86	S	
0.630	160516.0.630	✓	1.5kA @ 305V _{AC} ¹⁾	410	460	1.5	S	
0.800	160516.0.800	✓	1.5kA @ 305V _{AC} ¹⁾	350	490	2.6	S	
1	160516.1	✓	1.5kA @ 305V _{AC} ¹⁾	380	640	4.5	S	
1.25	160516.1.25	✓	1.5kA @ 305V _{AC} ¹⁾	340	790	4.1	S	
1.6	160516.1.6	✓	1.5kA @ 305V _{AC} ¹⁾	330	970	6.2	S	
2	160516.2	✓	1.5kA @ 305V _{AC} ¹⁾	280	1 060	13	S	
2.5	160516.2.5	✓	1.5kA @ 305V _{AC} ¹⁾	240	1 120	21	S	
3.15	160516.3.15	✓	1.5kA @ 305V _{AC} ¹⁾	200	1 200	35	S	
4	160516.4	✓	1.5kA @ 305V _{AC} ¹⁾	160	1 250	49	S	
5	160516.5	✓	1.5kA @ 277V _{AC} ¹⁾	140	1 300	92	S	
6.3	160516.6.3	✓	1.5kA @ 277V _{AC} ¹⁾	120	1 370	170	S	
8	160516.8	✓	1.5kA @ 250V _{AC} ¹⁾	90	1 250	160	S	
10	160516.10	✓	1.5kA @ 250V _{AC} ¹⁾	80	1 500	280	S	

¹⁾ 1.5kA @ 250V_{DC}

Time-Current Characteristics

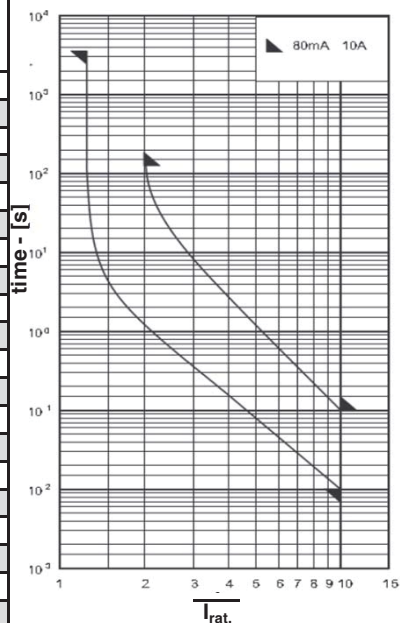

Tape reel ordering, add following suffix to article number

GT - (1 500 pieces on tape reel)

e.g. 160016.1.25GT

Dimensions [mm]

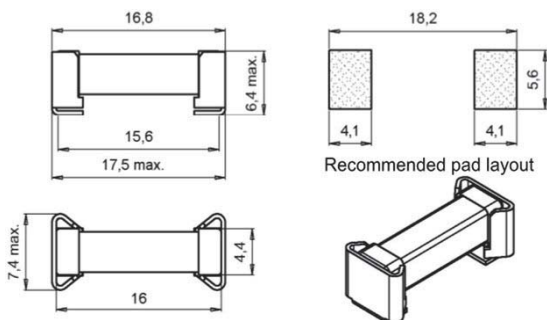

Rated current	Fusing Time Limits									
	1.25 I_n		2 I_n		2.75 I_n		4 I_n		10 I_n	
	Min	Max	Min	Max	Min	Max	Min	Max	Min	Max
80mA - 10A	1h	—	2ms	—	—	—	—	—	10ms	100ms

Resistance to soldering heat, 260°C, 10s, to IEC 60068

SIBA LLC

29 Fairfield Place

West Caldwell, New Jersey 07006

Phone 1-973-575-7422

Fax 1-973-575-5858

portal: www.siballc.net

e-mail: info@sibafuse.com

GSMB **Rated Voltage** **Rated Breaking Test** **Class** **Standard(s)**

RoHS

[Un] Voltage Capacity TT IEC 60127-4

250V_{AC} 250V_{AC} 35A



4.5mmx16mm - Ceramic tube, no filler, contacts - copper alloy - silver plated

Rated current I_n [A]	Article Number	Rated breaking current [A]	Voltage drop [mV]	Power dissipation @ 1.5 I_n [mW]	Pre-arcing I^2t @ 10 I_n [A ² s]	Approvals	Marking
0.160	163016.0.160	35A @ 250V _{AC} ¹⁾	*	—	—		
0.200	163016.0.200	35A @ 250V _{AC} ¹⁾	*	—	—		
0.250	163016.0.250	35A @ 250V _{AC} ¹⁾	*	—	—		
0.315	163016.0.315	35A @ 250V _{AC} ¹⁾	*	—	—		
0.400	163016.0.400	35A @ 250V _{AC} ¹⁾	190	190	4.5		
0.500	163016.0.500	35A @ 250V _{AC} ¹⁾	*	—	—		
0.630	163016.0.630	35A @ 250V _{AC} ¹⁾	*	—	—		
0.800	163016.0.800	35A @ 250V _{AC} ¹⁾	160	350	14		
1	163016.1	35A @ 250V _{AC} ¹⁾	160	550	23		
2	163016.2	35A @ 250V _{AC} ¹⁾	80	500	80		
2.5	163016.2.5	35A @ 250V _{AC} ¹⁾	*	—	—		

* Data on request

¹⁾ 35A @ 250V_{DC}

Tape reel ordering, add following suffix to article number
GT - (1 500 pieces on tape reel)
e.g. 163016.1.25GT

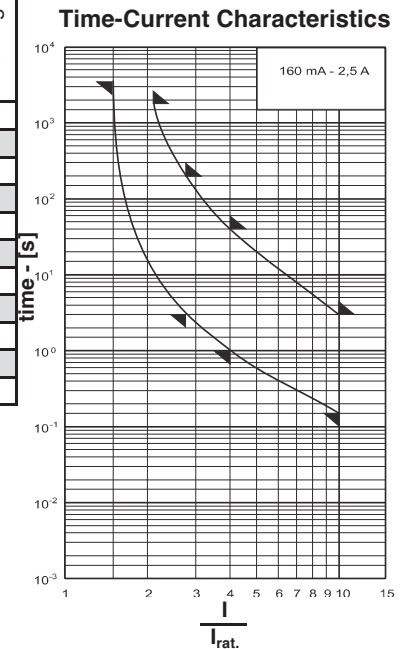

Dimensions [mm]

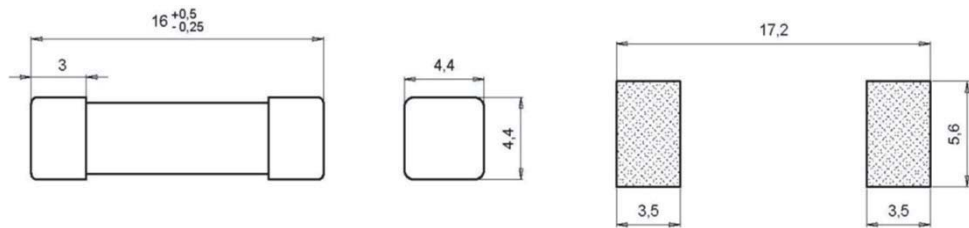

Recommended pad layout

Rated current	Fusing Time Limits									
	1.5 I_n		2.1 I_n		2.75 I_n		4 I_n		10 I_n	
	Min	Max	Min	Max	Min	Max	Min	Max	Min	Max
160mA - 2.5A	1h	—	30m	—	3s	200s	1s	40s	150ms	3s

Resistance to soldering heat, 260°C, 10s, to IEC 60068



Rated Voltage
[Un]
250V_{AC}

Rated Breaking Test
Voltage Capacity
250V_{AC} 35A / 10I_{rat}

Class
F

Standard(s)
IEC 60127-3/3
EN 60127-3/3
VDE 0820-3/3

8.4mmx7.6mm - Thermoplastic, temperature resistant, self extinguishing, contact leads - copper tin plated

Rated current I _n [A]	X=0, Long leads X=5, Short leads Article Number	UL rec	Rated breaking current [A]	Voltage drop [mV]	Power dissipation @ 1.5I _n [mW]	Pre-arcing I ² t [A ² s]	Approvals S - Semko	Marking
0.050	1640X0.0.050	✓	35A @ 250V _{AC}	820	95	0.0003	S	
0.063	1640X0.0.063	✓	35A @ 250V _{AC}	750	110	0.0007	S	
0.080	1640X0.0.080	✓	35A @ 250V _{AC}	630	120	0.0015	S	
0.100	1640X0.0.100	✓	35A @ 250V _{AC}	550	155	0.0035	S	
0.125	1640X0.0.125	✓	35A @ 250V _{AC}	500	175	0.006	S	
0.160	1640X0.0.160	✓	35A @ 250V _{AC}	460	210	0.011	S	
0.200	1640X0.0.200	✓	35A @ 250V _{AC}	150	80	0.018	S	
0.250	1640X0.0.250	✓	35A @ 250V _{AC}	140	90	0.036	S	
0.315	1640X0.0.315	✓	35A @ 250V _{AC}	130	120	0.050	S	
0.400	1640X0.0.400	✓	35A @ 250V _{AC}	120	140	0.10	S	
0.500	1640X0.0.500	✓	35A @ 250V _{AC}	110	160	0.18	S	
0.630	1640X0.0.630	✓	35A @ 250V _{AC}	100	180	0.33	S	
0.800	1640X0.0.800	✓	35A @ 250V _{AC}	90	200	0.14	S	
1	1640X0.1	✓	35A @ 250V _{AC}	80	220	0.24	S	
1.25	1640X0.1.25	✓	35A @ 250V _{AC}	75	260	0.35	S	
1.6	1640X0.1.6	✓	35A @ 250V _{AC}	70	350	0.60	S	
2	1640X0.2	✓	35A @ 250V _{AC}	65	380	1.2	S	
2.5	1640X0.2.5	✓	35A @ 250V _{AC}	60	420	2.0	S	
3.15	1640X0.3.15	✓	35A @ 250V _{AC}	60	580	3.5	S	
4	1640X0.4	✓	40A @ 250V _{AC}	60	700	6.2	S	
5	1640X0.5	✓	50A @ 250V _{AC}	60	900	13	S	
6.3	1640X0.6.3	✓	63A @ 250V _{AC}	60	1 100	19	S	

Time-Current Characteristics

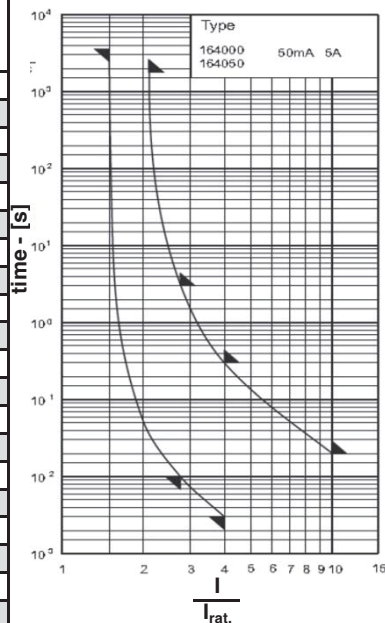

Tape reel ordering, add following suffix to article number
 GT - (1 000 pieces on tape reel)
 IP - (2 000 pieces industrial packs)
 e.g. 164000.3.15GT
 164050.0.800IP

164000

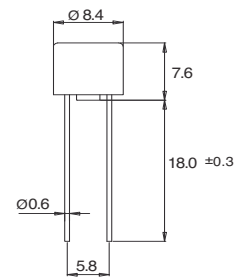

164050

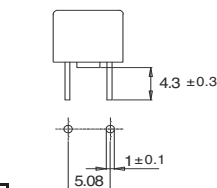



Rated current	Fusing Time Limits									
	1.5I _n		2.1I _n		2.75I _n		4I _n		10I _n	
	Min	Max	Min	Max	Min	Max	Min	Max	Min	Max
50mA - 6.3A	1h	—	30m	—	10ms	3s	3ms	300ms	—	20ms

Dimensions [mm]

Accessory

Sub-miniature fuse holder for PCB, Article Number 166602, see page 678

GKSR   **Rated Voltage** [Un] 250V_{AC} **Rated Breaking Test** Voltage 250V_{AC} Capacity 50A **Class** F **Standard(s)** UL 248-14 CSA C22.2 - No 248.14

E167295

8.4mmx7.6mm - Thermoplastic, temperature resistant, self extinguishing, contact leads - copper tin plated

Rated current I _n [A]	X=0, Long leads X=5, Short leads Article Number	UL listed	Rated breaking current [A]	Voltage drop [mV]	Power dissipation @ 1.0I _n [mW]	Pre-arcing I ² t [A ² s]	Approvals	Marking
0.050	1645X0.0.050	✓	50A @ 250V _{AC}	2 400	120	0.0001		
0.063	1645X0.0.063	✓	50A @ 250V _{AC}	1 350	85	0.0003		
0.080	1645X0.0.080	✓	50A @ 250V _{AC}	1 200	95	0.0007		
0.100	1645X0.0.100	✓	50A @ 250V _{AC}	1 100	110	0.0015		
0.125	1645X0.0.125	✓	50A @ 250V _{AC}	1 000	125	0.003		
0.160	1645X0.0.160	✓	50A @ 250V _{AC}	950	155	0.0075		
0.200	1645X0.0.200	✓	50A @ 250V _{AC}	850	170	0.013		
0.250	1645X0.0.250	✓	50A @ 250V _{AC}	240	60	0.02		
0.315	1645X0.0.315	✓	50A @ 250V _{AC}	230	75	0.03		
0.400	1645X0.0.400	✓	50A @ 250V _{AC}	220	90	0.055		
0.500	1645X0.0.500	✓	50A @ 250V _{AC}	210	105	0.1		
0.630	1645X0.0.630	✓	50A @ 250V _{AC}	200	130	0.19		
0.800	1645X0.0.800	✓	50A @ 250V _{AC}	190	155	0.36		
1	1645X0.1	✓	50A @ 250V _{AC}	180	180	0.14		
1.25	1645X0.1.25	✓	50A @ 250V _{AC}	170	215	0.24		
1.6	1645X0.1.6	✓	50A @ 250V _{AC}	160	260	0.34		
2	1645X0.2	✓	50A @ 250V _{AC}	150	300	0.56		
2.5	1645X0.2.5	✓	50A @ 250V _{AC}	140	350	1.1		
3.15	1645X0.3.15	✓	50A @ 250V _{AC}	130	410	2		
4	1645X0.4	✓	50A @ 250V _{AC}	120	480	3.2		
5	1645X0.5	✓	50A @ 250V _{AC}	110	550	6.2		
6.3	1645X0.6.3	✓	50A @ 250V _{AC}	100	630	14		
8	1645X0.8	✓	50A @ 250V _{AC}	90	720	24		
10	1645X0.10	✓	50A @ 250V _{AC}	90	900	40		

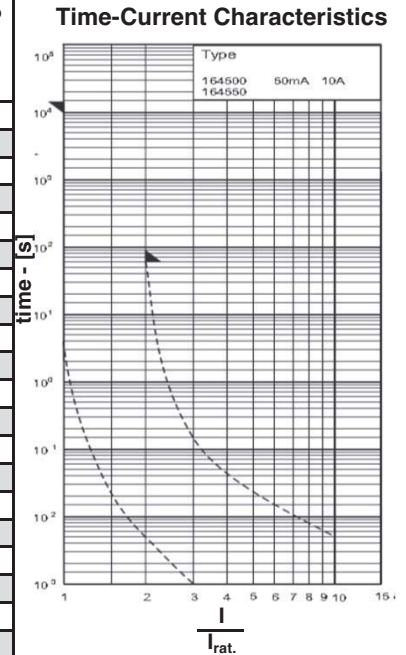

Tape reel ordering, add following suffix to article number
 GT - (1 000 pieces on tape reel)
 IP - (2 000 pieces)
 e.g. 164500.1.25GT
 164550.0.250IP

164500

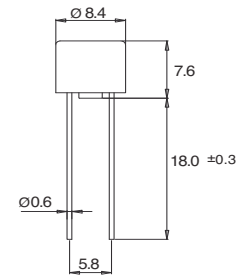

164550

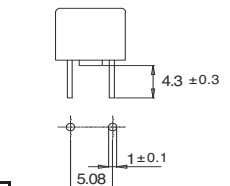

Rated current	Fusing Time Limits								Min	Max	
	1I _n		1.35I _n		1.50I _n		2.00I _n				
50mA - 10A	4h	—	—	—	—	—	—	—	60s	—	—

Dimensions [mm]

Accessory

Sub-miniature fuse holder for PCB, Article Number 166602, see page 678

GKSR



Rated Voltage

[Un]
250V_{AC}

Rated Breaking Test

Voltage Capacity
250V_{AC} 35A / 10I_{rat}

Class

M

Standard(s)

IEC 60127-3



8.4mmx7.6mm - Thermoplastic, temperature resistant, self extinguishing, contact leads - copper tin plated

Rated current I _n [A]	X=0, Long leads X=5, Short leads Article Number	Rated breaking current [A]	Voltage drop [mV]	Power dissipation @ 1.5I _n [mW]	Pre-arcing I ² t [A ² s]	Approvals	Marking
0.160	1650X0.0.160	35A @ 250V _{AC}	325	140	0.075		
0.200	1650X0.0.200	35A @ 250V _{AC}	120	80	0.02		
0.250	1650X0.0.250	35A @ 250V _{AC}	120	90	0.036		
0.315	1650X0.0.315	35A @ 250V _{AC}	120	120	0.055		
0.400	1650X0.0.400	35A @ 250V _{AC}	110	140	0.11		
0.500	1650X0.0.500	35A @ 250V _{AC}	100	160	0.2		
0.630	1650X0.0.630	35A @ 250V _{AC}	90	180	0.33		
0.800	1650X0.0.800	35A @ 250V _{AC}	80	140	0.58		
1	1650X0.1	35A @ 250V _{AC}	70	160	0.9		
1.25	1650X0.1.25	35A @ 250V _{AC}	65	190	1.4		
1.6	1650X0.1.6	35A @ 250V _{AC}	65	200	2.5		
2	1650X0.2	35A @ 250V _{AC}	60	350	3.1		
2.5	1650X0.2.5	35A @ 250V _{AC}	55	380	5.2		
3.15	1650X0.3.15	35A @ 250V _{AC}	55	510	9.9		
4	1650X0.4	40A @ 250V _{AC}	50	550	16		

Time-Current Characteristics

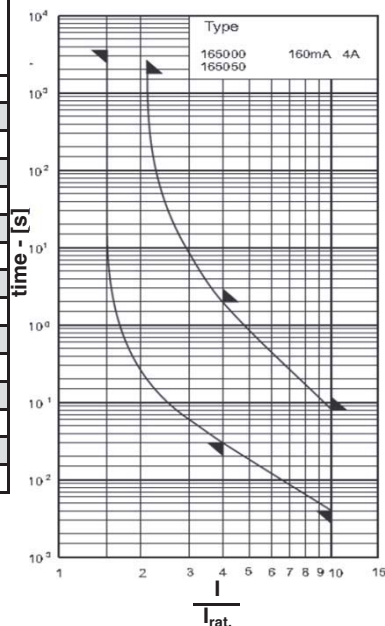

Tape reel ordering, add following suffix to article number

GT - (1 000 pieces on tape reel)

IP - (2 000 pieces)

e.g. 165000.1.25GT

165050.0.630IP

165000

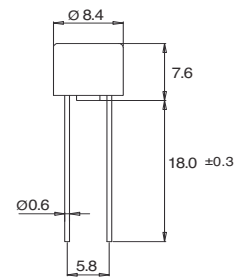

165050

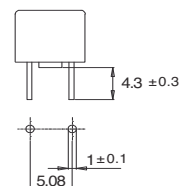

Rated current	Fusing Time Limits									
	1.5I _n		2.1I _n		2.75I _n		4I _n		10I _n	
	Min	Max	Min	Max	Min	Max	Min	Max	Min	Max
160mA - 4A	1h	—	—	30m	—	—	30ms	2s	4ms	80ms

Dimensions [mm]

Accessory

Sub-miniature fuse holder for PCB, Article Number 166602, see page 678

SIBA LLC

29 Fairfield Place



West Caldwell, New Jersey 07006

Phone 1-973-575-7422

Fax 1-973-575-5858

portal: www.siballc.net

e-mail: info@sibafuse.com

GKSR   

Rated Voltage [Un] **Rated Breaking Test** **Class** **Standard(s)**
 250V_{AC} Voltage Capacity T IEC 60127-3/4
 250V_{AC} 35A / 10I_{rat} EN 60127-3/4
 VDE 0820- 3/4

E167295
 8.4mmx7.6mm - Thermoplastic, temperature resistant, self extinguishing, contact leads - copper tin plated

Rated current I _n [A]	X=0, Long leads X=5, Short leads Article Number	UL rec	Rated breaking current [A]	Voltage drop [mV]	Power dissipation @ 1.5I _n [mW]	Pre-arcing I ² t [A ² s]	Approvals S - Semko V - VDE	Marking
0.040	1660X0.0.040	✓	35A @ 250V _{AC}	530	60	0.015	S V	
0.050	1660X0.0.050	✓	35A @ 250V _{AC}	490	70	0.017	S V	
0.063	1660X0.0.063	✓	35A @ 250V _{AC}	390	80	0.02	S V	
0.080	1660X0.0.080	✓	35A @ 250V _{AC}	300	90	0.035	S V	
0.100	1660X0.0.100	✓	35A @ 250V _{AC}	260	100	0.06	S V	
0.125	1660X0.0.125	✓	35A @ 250V _{AC}	180	110	0.12	S V	
0.160	1660X0.0.166	✓	35A @ 250V _{AC}	170	130	0.21	S V	
0.200	1660X0.0.200	✓	35A @ 250V _{AC}	160	140	0.32	S V	
0.250	1660X0.0.250	✓	35A @ 250V _{AC}	150	150	0.50	S V	
0.315	1660X0.0.315	✓	35A @ 250V _{AC}	140	160	0.8	S V	
0.400	1660X0.0.400	✓	35A @ 250V _{AC}	130	170	1.1	S V	
0.500	1660X0.0.500	✓	35A @ 250V _{AC}	120	180	1.8	S V	
0.630	1660X0.0.630	✓	35A @ 250V _{AC}	110	200	3.2	S V	
0.800	1660X0.0.800	✓	35A @ 250V _{AC}	100	220	5.2	S V	
1	1660X0.1	✓	35A @ 250V _{AC}	85	240	8	S V	
1.25	1660X0.1.25	✓	35A @ 250V _{AC}	75	290	12	S V	
1.6	1660X0.1.6	✓	35A @ 250V _{AC}	70	350	22	S V	
2	1660X0.2	✓	35A @ 250V _{AC}	70	480	30	S V	
2.5	1660X0.2.5	✓	35A @ 250V _{AC}	70	520	46	S V	
3.15	1660X0.3.15	✓	35A @ 250V _{AC}	70	600	80	S V	
4	1660X0.4	✓	40A @ 250V _{AC}	70	800	130	S V	
5	1660X0.5	✓	50A @ 250V _{AC}	70	1 000	130	S V	
6.3	1660X0.6.3	✓	63A @ 250V _{AC}	70	1 200	230	S V	

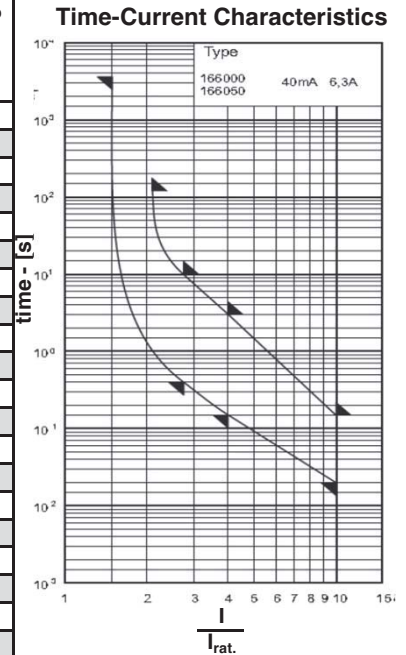

Tape reel ordering, add following suffix to article number
 GT - (1 000 pieces on tape reel)
 IP - (2 000 pieces)
 e.g. 166000.3.15GT
 166050.0.080IP

166000

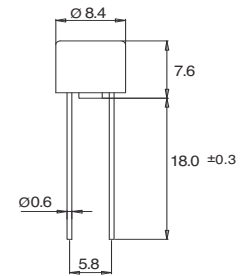

166050

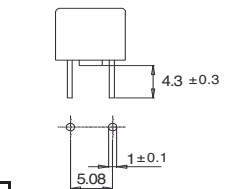

Rated current	Fusing Time Limits									
	1.5I _n		2.1I _n		2.75I _n		4I _n		10I _n	
	Min	Max	Min	Max	Min	Max	Min	Max	Min	Max
40mA - 6.3A	1h	—	—	2m	400ms	10s	150ms	3s	20ms	150ms

Dimensions [mm]

Accessory

Sub-miniature fuse holder for PCB, Article Number 166602, see page 678

GKSR

Rated Voltage

Rated Breaking Test

Class

Standard(s)



[Un]
250V_{AC}

Voltage
250V_{AC}

Capacity
50A

T

UL 248-14

CSA C22.2 -

No 248.14



E167295

8.4mmx7.6mm - Thermoplastic, temperature resistant, self extinguishing, contact leads - copper tin plated

Rated current I_n [A]	X=0, Long Leads X=5, Short Leads Article Number	UL listed	Rated breaking current [A]	Voltage drop [mV]	Power dissipation @ 1.5 I_n [mW]	Pre-arcing I^2t [A ² s]	Approvals UL and cUL	Marking
0.050	1665X0.0.050	✓	50A @ 250V _{AC}	800	40	0.015	✓	
0.063	1665X0.0.063	✓	50A @ 250V _{AC}	700	45	0.017	✓	
0.080	1665X0.0.080	✓	50A @ 250V _{AC}	600	50	0.02	✓	
0.100	1665X0.0.100	✓	50A @ 250V _{AC}	500	50	0.025	✓	
0.125	1665X0.0.125	✓	50A @ 250V _{AC}	400	50	0.03	✓	
0.160	1665X0.0.160	✓	50A @ 250V _{AC}	350	55	0.07	✓	
0.200	1665X0.0.200	✓	50A @ 250V _{AC}	300	60	0.14	✓	
0.250	1665X0.0.250	✓	50A @ 250V _{AC}	250	65	0.25	✓	
0.315	1665X0.0.315	✓	50A @ 250V _{AC}	240	75	0.42	✓	
0.400	1665X0.0.400	✓	50A @ 250V _{AC}	230	95	0.53	✓	
0.500	1665X0.0.500	✓	50A @ 250V _{AC}	220	110	1.0	✓	
0.630	1665X0.0.630	✓	50A @ 250V _{AC}	170	110	1.5	✓	
0.800	1665X0.0.800	✓	50A @ 250V _{AC}	150	120	3.1	✓	
1	1665X0.1	✓	50A @ 250V _{AC}	130	130	4.8	✓	
1.25	1665X0.1.25	✓	50A @ 250V _{AC}	150	190	5.7	✓	
1.6	1665X0.1.6	✓	50A @ 250V _{AC}	145	235	11	✓	
2	1665X0.2	✓	50A @ 250V _{AC}	125	250	18	✓	
2.5	1665X0.2.5	✓	50A @ 250V _{AC}	120	300	25	✓	
3.15	1665X0.3.15	✓	50A @ 250V _{AC}	110	350	40	✓	
4	1665X0.4	✓	50A @ 250V _{AC}	100	400	72	✓	
5	1665X0.5	✓	50A @ 250V _{AC}	95	475	130	✓	
6.3	1665X0.6.3	✓	50A @ 250V _{AC}	90	570	130	✓	
8	1665X0.8	✓	50A @ 250V _{AC}	90	720	230	✓	
10	1665X0.10	✓	50A @ 250V _{AC}	90	900	370	✓	

Time-Current Characteristics

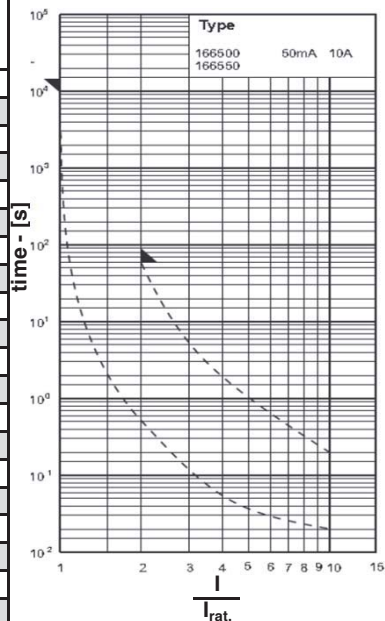

Tape reel ordering, add following suffix to article number
 GT - (1 000 pieces on tape reel)
 IP - (2 000 pieces)
 e.g. 166500.3.15GT
 166500.9.160IP

166500

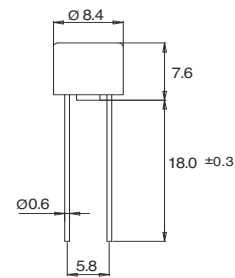

166550

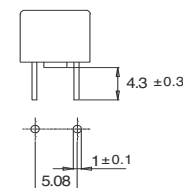

Rated current	Fusing Time Limits									
	1 I_n		1.35 I_n		1.50 I_n		2.00 I_n			
	Min	Max	Min	Max	Min	Max	Min	Max	Min	Max
50mA - 10A	4h	—	—	—	—	—	—	—	60s	—

Dimensions [mm]

Accessory

Sub-miniature fuse holder for PCB, Article Number 166602, see page 678

SIBA LLC

29 Fairfield Place
 West Caldwell, New Jersey 07006

Phone 1-973-575-7422
 Fax 1-973-575-5858

portal: www.siballc.net
 e-mail: info@sibafuse.com

GZ **Rated Voltage** [Un] **Rated Breaking Test** **Class** **Standard(s)**
 250V_{AC} **Voltage** **Capacity** **FF** **Special Type**
 E180276 200kA / 1.5kA
 5mmx20mm - Ceramic tube w/ filler, end caps - brass, nickel plated

Rated current I_n [A]	Article Number	UL rec	Rated breaking current [A]	Voltage drop [mV]	Power dissipation @ 1.0 I_n [mW]	Pre-arcing I^2t [A ² s]	Approvals
0.100	7000140.0.100		200kA @ 250V _{AC}	4 000	0.4	0.0016	
0.125	7000140.0.125	✓	200kA @ 250V _{AC}	3 500	0.5	0.0024	
0.160	7000140.0.160	✓	200kA @ 250V _{AC}	1 300	0.3	0.004	
0.200	7000140.0.200	✓	200kA @ 250V _{AC}	600	0.2	0.01	
0.250	7000140.0.250	✓	200kA @ 250V _{AC}	550	0.2	0.02	
0.315	7000140.0.315	✓	200kA @ 250V _{AC}	500	0.2	0.04	
0.400	7000140.0.400	✓	200kA @ 250V _{AC}	500	0.2	0.07	
0.500	7000140.0.500	✓	200kA @ 250V _{AC}	550	0.3	0.07	
0.630	7000140.0.630	✓	200kA @ 250V _{AC}	600	0.4	0.15	
0.800	7000140.0.800	✓	300kA @ 250V _{AC}	600	0.5	0.32	
1	7000140.1	✓	200kA @ 250V _{AC}	600	0.6	0.32	
1.25	7000140.1.25	✓	200kA @ 250V _{AC}	400	0.5	0.20	
1.6	7000140.1.6	✓	200kA @ 250V _{AC}	400	0.7	0.31	
2	7000140.2	✓	200kA @ 250V _{AC}	400	0.8	0.64	
2.5	7000140.2.5	✓	200kA @ 250V _{AC}	400	1.0	0.88	
3.15	7000140.3.15	✓	200kA @ 250V _{AC}	400	1.3	1.6	
4	7000140.4	✓	200kA @ 250V _{AC}	350	1.4	3.2	
5	7000140.5	✓	200kA @ 250V _{AC}	350	1.8	5.9	
6.3	7000140.6.3		1.5kA @ 250V _{AC}	300	1.9	10	
8	7000140.8		1.5kA @ 250V _{AC}	300	2.4	19	
10	7000140.10		1.5kA @ 250V _{AC}	300	3.0	30	
12.5	7000140.12.5		1.5kA @ 250V _{AC}	200	2.5	115	

Time-Current Characteristics

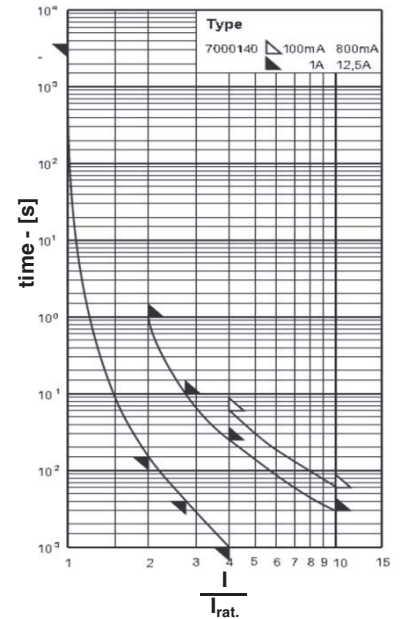

Weight (kg per 100)
0.14
Units per package
10

For 6.3A and higher, consideration should be given to heat dissipation

IP - (1 000 pieces)
e.g. 7000140.3.15IP



Dimensions [mm]

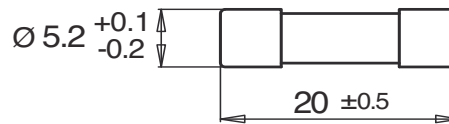

Rated current	Fusing Time Limits									
	1 I_n		2 I_n		2.75 I_n		4 I_n		10 I_n	
	Min	Max	Min	Max	Min	Max	Min	Max	Min	Max
100mA - 800A	1h	—	—	—	—	—	—	60ms	—	6ms
1A - 12.5A	1h	—	—	1s	4ms	100ms	1ms	25ms	—	3ms

GZ **Rated Voltage** [Un] **Rated Breaking Test** Voltage Capacity **Class** FF **Standard(s)** Special Type

E180276
5mmx20mm - Ceramic tube w/ filler, end caps - brass, nickel plated

Rated current I_n [A]	Article Number	UL rec	Rated breaking current [A]	Voltage drop [mV]	Power dissipation @ $1.0I_n$ [mW]	Pre-arcing I^2t [A ² s]	Approvals
0.100	7000740.0.100		10kA @ 400V _{AC} ¹	4 000	0.4	0.0016	
0.125	7000740.0.125		10kA @ 400V _{AC} ¹	3 500	0.5	0.0024	
0.160	7000740.0.160		10kA @ 400V _{AC} ¹	1 300	0.3	0.004	
0.200	7000740.0.200		10kA @ 400V _{AC} ¹	600	0.2	0.01	
0.250	7000740.0.250		10kA @ 400V _{AC} ¹	550	0.2	0.02	
0.315	7000740.0.315		10kA @ 400V _{AC} ¹	500	0.2	0.04	
0.400	7000740.0.400		10kA @ 400V _{AC} ¹	500	0.2	0.07	
0.500	7000740.0.500		10kA @ 400V _{AC} ¹	550	0.3	0.07	
0.630	7000740.0.630		10kA @ 400V _{AC} ¹	600	0.4	0.15	
0.800	7000740.0.800		10kA @ 400V _{AC} ¹	600	0.5	0.32	
1	7000740.1		10kA @ 400V _{AC} ¹	600	0.6	0.32	
1.25	7000740.1.25		10kA @ 400V _{AC} ¹	400	0.5	0.20	
1.6	7000740.1.6		10kA @ 400V _{AC} ¹	400	0.7	0.31	
2	7000740.2		10kA @ 400V _{AC} ¹	400	0.8	0.64	
2.5	7000740.2.5		10kA @ 400V _{AC} ¹	400	1.0	0.88	
3.15	7000740.3.15		10kA @ 400V _{AC} ¹	400	1.3	1.6	
4	7000740.4		10kA @ 400V _{AC} ¹	350	1.4	3.2	
1) $\cos\phi = 0.7$							
@ $1.5I_n$							
6.3	7000740.6.3	✓	200kA @ 250V _{AC} ²	250	2.8	1.6	
8	7000740.8	✓	200kA @ 250V _{AC} ²	230	3.0	4.5	
10	7000740.10	✓	200kA @ 250V _{AC} ²	180	3.4	8.8	
12.5	7000740.12.5	✓	200kA @ 250V _{AC} ²	150	4.0	15	
16	7000740.16		10kA @ 125V _{AC}	130	3.8	46	

Weight (kg per 100)	2) $\cos\phi = 0.2$
0.14	For 6.3A and higher, consideration should be given to heat dissipation
Units per package	
10	



Dimensions [mm]

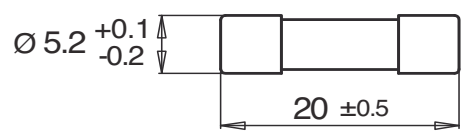

Time-Current Characteristics

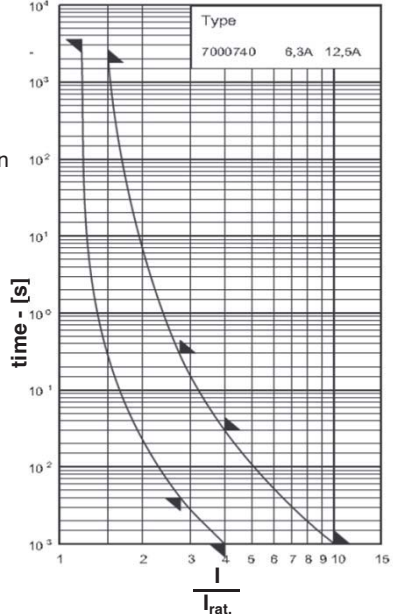
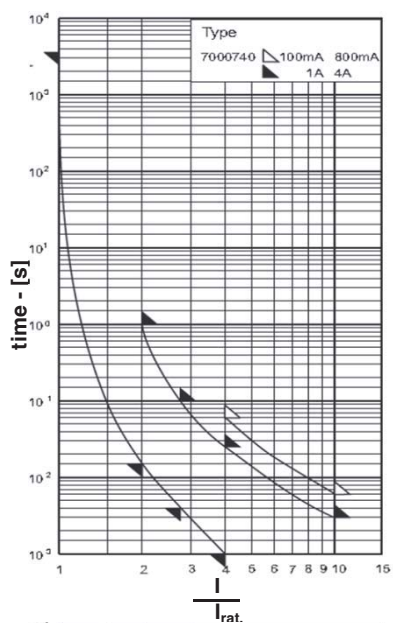

Rated current	Fusing Time Limits									
	$1I_n$		$2I_n$		$2.75I_n$		$4I_n$		$10I_n$	
	Min	Max	Min	Max	Min	Max	Min	Max	Min	Max
100mA - 800A	1	h	—	—	—	—	—	60ms	—	6ms
1A - 4A	1h	—	—	1s	4ms	100ms	1ms	25ms	—	3ms
Rated current	$1.2I_n$		$1.5I_n$		$2.75I_n$		$4I_n$		$10I_n$	
6.3A - 12.5A	1h	—	—	30m	4ms	300ms	1ms	30ms	—	1ms

GZ **Rated Voltage** **Rated Breaking Test** **Class** **Standard(s)**

RoHS

[Un]
660V_{AC/DC}

Voltage
660V_{AC/DC}

Capacity
100kA

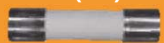
aR(FF)

Special Type
(Short circuit protection only)

5mmx20mm - Ceramic tube w/ filler, end caps - brass, nickel plated Short Circuit Protection Only

Rated current I_n [A]	Article Number	Rated breaking current [A]	Voltage drop [mV]	Power dissipation @ 1.0 I_n [mW]	Pre-arcing I^2t [A ² s]	Approvals
0.100	7018040.0.100	100kA @660V _{AC/DC}	1 000	0.1	0.0009	
0.200	7018040.0.200	100kA @660V _{AC/DC}	600	0.2	0.01	
0.250	7018040.0.250	100kA @660V _{AC/DC}	550	0.2	0.02	
0.500	7018040.0.500	100kA @660V _{AC/DC}	550	0.3	0.07	

Weight (kg per 100)	0.14
Units per package	10

Time-Current Characteristics

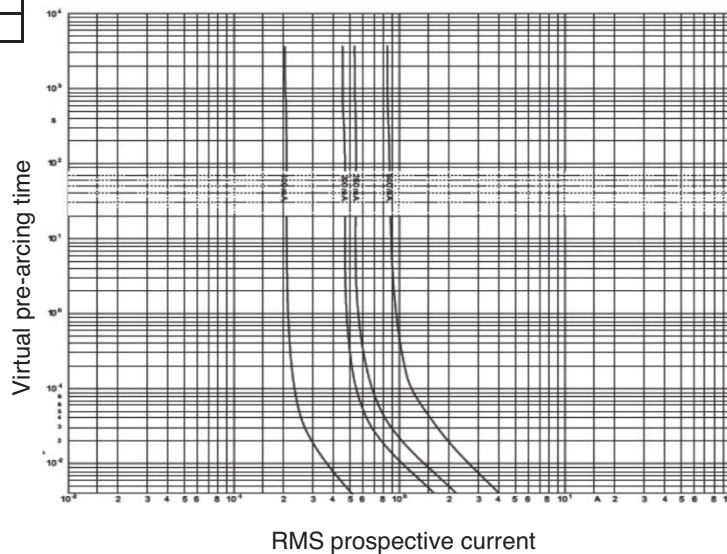

Dimensions [mm]



Rated current	Fusing Time Limits									
	1 I_n		2 I_n		2.75 I_n		4 I_n		10 I_n	
	Min	Max	Min	Max	Min	Max	Min	Max	Min	Max
100mA - 500mA	1h	—	—	—	—	—	—	60ms	—	6ms

GZ

Rated Voltage [Un] 250V_{AC} | Rated Breaking Test Voltage 250V_{AC} Capacity 35A / 10I_{rat} | Class F | Standard(s) IEC 60127-2/2, EN 60127-2/2, VDE 0820 - 2/2

E167295 | 5mmx20mm - Glass tube, end caps - brass, nickel plated

Rated current I _n [A]	Article Number	UL rec	Rated breaking current [A]	Voltage drop [mV]	Power dissipation @ 1.5I _n [W]	Pre-arcing I ² t [A ² s]	Approvals S - Semko, V - VDE, B - BEAB
0.050	179020.0.050	✓	35A @ 250V _{AC}	3 500	0.4	0.0004	S V
0.063	179020.0.063	✓	35A @ 250V _{AC}	3 500	0.5	0.0007	S V B
0.080	179020.0.080	✓	35A @ 250V _{AC}	2 500	0.5	0.0017	S V B
0.100	179020.0.100	✓	35A @ 250V _{AC}	2 200	0.6	0.0022	S V B
0.125	179020.0.125	✓	35A @ 250V _{AC}	350	0.2	0.01	S V B
0.160	179020.0.160	✓	35A @ 250V _{AC}	310	0.2	0.02	S V B
0.200	179020.0.200	✓	35A @ 250V _{AC}	290	0.2	0.037	S V B
0.250	179020.0.250	✓	35A @ 250V _{AC}	280	0.2	0.073	S V B
0.315	179020.0.315	✓	35A @ 250V _{AC}	230	0.3	0.016	S V B
0.400	179020.0.400	✓	35A @ 250V _{AC}	200	0.3	0.032	S V B
0.500	179020.0.500	✓	35A @ 250V _{AC}	160	0.3	0.16	S V B
0.630	179020.0.630	✓	35A @ 250V _{AC}	140	0.3	0.39	S V B
0.700	179020.0.700	✓	35A @ 250V _{AC}	140	0.3	0.56	
0.800	179020.0.800	✓	35A @ 250V _{AC}	130	0.4	0.8	S V B
1	179020.1	✓	35A @ 250V _{AC}	130	0.4	1.5	S V B
1.25	179020.1.25	✓	35A @ 250V _{AC}	120	0.5	2.0	S V B
1.4	179020.1.4	✓	35A @ 250V _{AC}	120	0.6	2.5	
1.5	179020.1.5	✓	35A @ 250V _{AC}	120	0.6	3.2	
1.6	179020.1.6	✓	35A @ 250V _{AC}	120	0.7	4.1	S V B
2	179020.2	✓	35A @ 250V _{AC}	120	0.7	6.2	S V B
2.5	179020.2.5	✓	35A @ 250V _{AC}	120	0.9	11	S V B
3.15	179020.3.15	✓	35A @ 250V _{AC}	120	1.0	20	S V B
3.5	179020.3.5		35A @ 250V _{AC}	110	1.2	20	
4	179020.4	✓	40A @ 250V _{AC}	100	1.3	25	S V B
5	179020.5	✓	50A @ 250V _{AC}	100	1.4	42	S V B
6.3	179020.6.3	✓	63A @ 250V _{AC}	100	1.7	79	S V B
8	179020.8		80A @ 250V _{AC}	100	2.0	125	
10	179020.10		100A @ 250V _{AC}	100	2.4	220	

Weight (kg per 100)
0.14



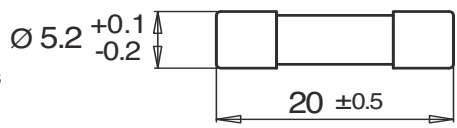

Dimensions [mm]

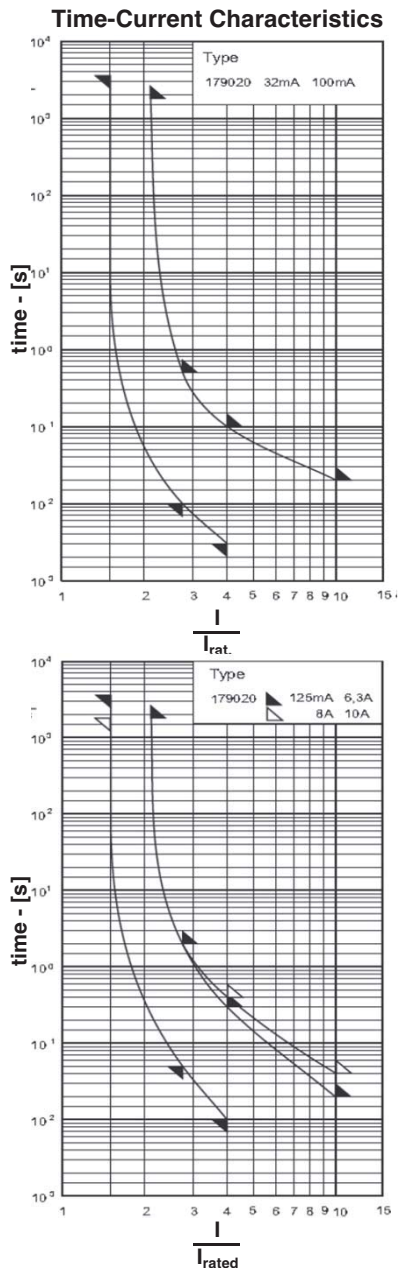

FC - 1 000 pieces with color code
 AK - with assembled leaded caps
 IP - (1 000 pieces)
 e.g. 179020.3.15IP



Rated current	Fusing Time Limits									
	1.5I _n		2.1I _n		2.75I _n		4I _n		10I _n	
	Min	Max	Min	Max	Min	Max	Min	Max	Min	Max
32mA - 100mA	1h	—	—	30m	10ms	500ms	3ms	100ms	—	20ms
125mA - 6.3A	1h	—	—	30m	50ms	2s	10ms	300ms	—	20ms
8A - 10A	30m	—	—	30m	50ms	2s	10ms	400ms	—	40ms

GZ   **Rated Voltage** [Un] **Rated Breaking Test** **Class** **Standard(s)**

250V_{AC} **250V_{AC}** **F** **IEC 60127-2/1**

250V_{DC} **250V_{DC}** **1.5kA / 1.0kA** **EN 60127-2/1**

1.5kA, IEC; 400mA - 4A **VDE 0820 - 2/1**

5mmx20mm - Ceramic tube w/ filler, end caps - brass, nickel plated

Rated current I _n [A]	Article Number	UL rec	Rated breaking current [A]	Voltage drop [mV]	Power dissipation @ 1.5I _n [W]	Pre-arcing I ² t [A ² s]	Approvals S - Semko
0.050	179021.0.050		1.5kA @ 250V _{AC}	4 000	0.5	0.00022	S
0.063	179021.0.063		1.5kA @ 250V _{AC}	3 900	0.6	0.00037	S
0.080	179021.0.080		1.5kA @ 250V _{AC}	3 200	0.7	0.00073	S
0.100	179021.0.100		1.5kA @ 250V _{AC}	2 600	0.8	0.0011	S
0.125	179021.0.125		1.5kA @ 250V _{AC}	360	0.2	0.01	S
0.160	179021.0.160		1.5kA @ 250V _{AC}	320	0.2	0.02	S
0.200	179021.0.200	✓	1.5kA @ 250V _{AC}	290	0.2	0.04	S
0.250	179021.0.250	✓	1.5kA @ 250V _{AC}	280	0.3	0.07	S
0.315	179021.0.315	✓	1.5kA @ 250V _{AC}	230	0.3	0.07	S
0.400	179021.0.400	✓	1.5kA @ 250V _{AC}	650	0.9	0.17	S
0.500	179021.0.500	✓	1.5kA @ 250V _{AC}	600	1.0	0.23	S
0.630	179021.0.630	✓	1.5kA @ 250V _{AC}	550	1.1	0.31	S
0.800	179021.0.800	✓	1.5kA @ 250V _{AC}	500	1.3	0.47	S
1	179021.1	✓	1.5kA @ 250V _{AC}	450	1.4	0.25	S
1.25	179021.1.25	✓	1.5kA @ 250V _{AC}	400	1.6	0.39	S
1.6	179021.1.6	✓	1.5kA @ 250V _{AC}	350	1.8	0.45	S
2	179021.2	✓	1.5kA @ 250V _{AC}	320	2.0	0.88	S
2.5	179021.2.5	✓	1.5kA @ 250V _{AC}	270	2.1	1.2	S
3.15	179021.3.15	✓	1.5kA @ 250V _{AC}	220	2.2	4	S
4	179021.4	✓	1.5kA @ 250V _{AC}	180	2.3	10	S
5	179021.5	✓	1.5kA @ 250V _{AC}	150	2.4	19	S
6.3	179021.6.3	✓	1.5kA @ 250V _{AC}	130	2.6	32	S
8	179021.8	✓	1.5kA @ 250V _{AC}	100	2.8	120	
10	179021.10	✓	1.5kA @ 250V _{AC}	100	3.0	190	
12.5	179021.12.5		1.0kA @ 250V _{AC}	100	3.4	300	
16	179021.16		1.0kA @ 250V _{AC}	100	4.0	600	

Weight (kg per 100)
0.14
Units per package
10

¹⁾ cosφ = 0.7 - 0.8
IEC; 400mA - 4A 1.5kA @ 250V_{DC} Non standard ratings also available



Dimensions [mm]

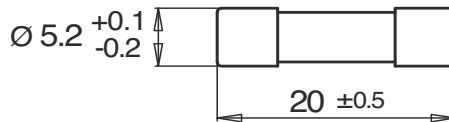

FC - 1 000 pieces with color code
AK - with assembled leaded caps
IP - (1 000 pieces)
e.g. 179021.2.5IP

Time-Current Characteristics

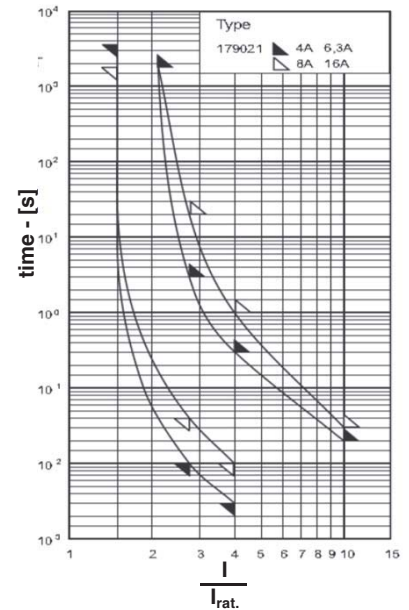
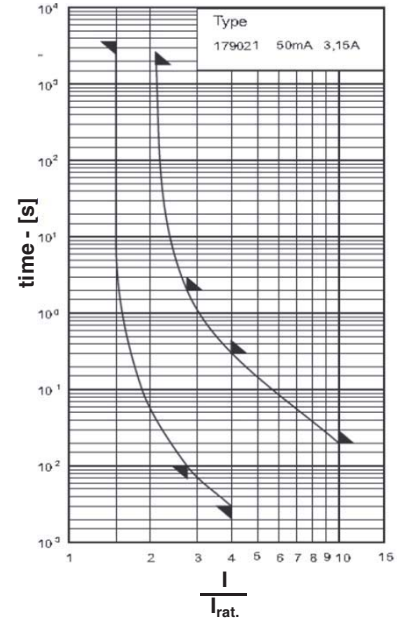

Rated current	Fusing Time Limits									
	1.5I _n		2.1I _n		2.75I _n		4I _n		10I _n	
	Min	Max	Min	Max	Min	Max	Min	Max	Min	Max
50mA - 3.15mA	1h	—	—	30m	10ms	2s	3ms	300ms	—	20ms
4A - 6.3A	1h	—	—	30m	10ms	3s	3ms	300ms	—	20ms
8A - 16A	30m	—	—	30m	40ms	20s	10ms	1s	—	30ms

GZ **Rated Voltage** **Rated Breaking Test** **Class** **Standard(s)**
[Un] **Voltage** **Capacity** **F** **DIN 41571-1**
250V_{AC} **250V_{AC}** **1kA / 300A** 

RoHS

5mmx20mm - Glass tube w/ filler, end caps - brass, nickel plated

Rated current I_n [A]	Article Number	Rated breaking current [A]	Voltage drop [mV]	Power dissipation @ $1.5I_n$ [W]	Pre-arcing I^2t [A ² s]	Approvals
1.6	171100.1.6	1.0kA @ 250V _{AC}	480	1.3	1.1	
2	171100.2	1.0kA @ 250V _{AC}	400	1.5	2	
2.5	171100.2.5	1.0kA @ 250V _{AC}	400	1.6	4	
3.15	171100.3.15	1.0kA @ 250V _{AC}	240	1.7	9	
4	171100.4	1.0kA @ 250V _{AC}	240	1.9	18	
5	171100.5	1.0kA @ 250V _{AC}	230	2.3	32	
6.3	171100.6.3	1.0kA @ 250V _{AC}	170	2.8	52	
8	171100.8	300A @ 250V _{AC}	160	3.2	100	
10	171100.10	300A @ 250V _{AC}	150	3.4	200	

Weight (kg per 100)	Non standard ratings also available
0.14	
Units per package	
10	

IP - (1 000 pieces)
e.g. 171100.3.15IP

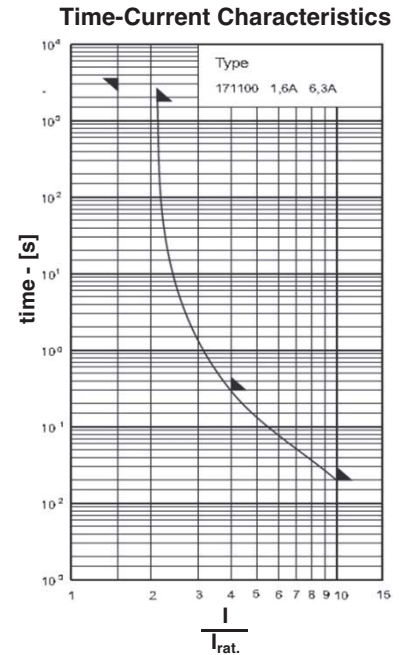

Dimensions [mm]

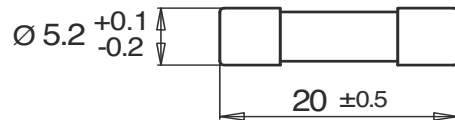

Rated current	Fusing Time Limits									
	1.5I _n		2.1I _n		2.75I _n		4I _n		10I _n	
	Min	Max	Min	Max	Min	Max	Min	Max	Min	Max
1.6A - 6.3A	1h	—	—	30m	—	—	—	300ms	—	20ms

GZ **Rated Voltage** **Rated Breaking Test** **Class** **Standard(s)**

RoHS

[Un] Voltage Capacity M DIN 41571-2

250V_{AC} 250V_{AC} 80A / 1kA / 300A

5mmx20mm - Glass tube w/ filler, end caps - brass, nickel plated

Rated current I_n [A]	Article Number	Rated breaking current [A]	Voltage drop [mV]	Power dissipation @ 1.5I _n [W]	Pre-arcing I ² t [A ² s]	Approvals
No Filler						
0.032	172000.0.032	80A @ 250V _{AC}	560	0.1	0.0055	
0.040	172000.0.040	80A @ 250V _{AC}	490	0.1	0.0008	
0.050	172000.0.050	80A @ 250V _{AC}	440	0.1	0.0013	
0.063	172000.0.063	80A @ 250V _{AC}	330	0.1	0.025	
0.080	172000.0.080	80A @ 250V _{AC}	490	0.1	0.04	
0.100	172000.0.100	80A @ 250V _{AC}	330	0.1	0.07	
0.125	172000.0.125	80A @ 250V _{AC}	230	0.1	0.018	
0.160	172000.0.160	80A @ 250V _{AC}	220	0.1	0.036	
0.200	172000.0.200	80A @ 250V _{AC}	190	0.2	0.07	
0.250	172000.0.250	80A @ 250V _{AC}	150	0.2	0.19	
0.315	172000.0.315	80A @ 250V _{AC}	140	0.2	0.35	
0.400	172000.0.400	80A @ 250V _{AC}	130	0.2	0.49	
0.500	172000.0.500	80A @ 250V _{AC}	120	0.2	0.9	
0.630	172000.0.630	80A @ 250V _{AC}	110	0.2	1.4	
0.700	172000.0.700	80A @ 250V _{AC}	140	0.3	1.6	
0.800	172000.0.800	80A @ 250V _{AC}	100	0.3	3.2	
1	172000.1	80A @ 250V _{AC}	90	0.3	6.5	
1.25	172000.1.25	80A @ 250V _{AC}	80	0.3	5	
with Filler						
1.4	172100.1.4	1.0kA @ 250V _{AC}	160	0.7	2.8	
1.5	172100.1.5	1.0kA @ 250V _{AC}	160	0.8	3.0	
1.6	172100.1.6	1.0kA @ 250V _{AC}	150	0.8	6.1	
2	172100.2	1.0kA @ 250V _{AC}	130	0.8	5.2	
2.5	172100.2.5	1.0kA @ 250V _{AC}	110	0.9	10	
3.15	172100.3.15	1.0kA @ 250V _{AC}	100	1.0	20	
4	172100.4	1.0kA @ 250V _{AC}	90	1.1	37	
5	172100.5	1.0kA @ 250V _{AC}	90	1.3	72	
6.3	172100.6.3	1.0kA @ 250V _{AC}	90	1.6	130	
8	172100.8	300A @ 250V _{AC}	90	2.0	230	
10	172100.10	300A @ 250V _{AC}	90	2.5	370	

Time-Current Characteristics

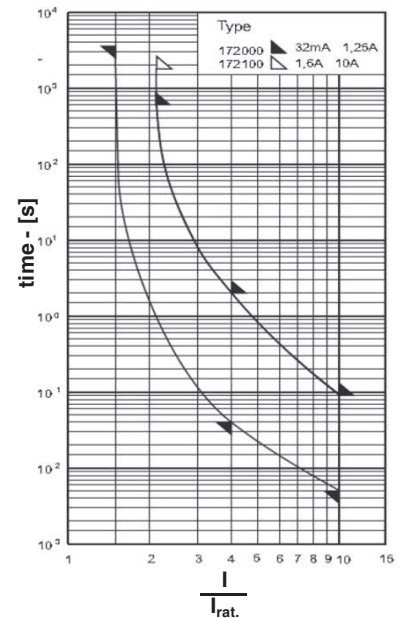

Weight (kg per 100)
0.14
Units per package
10



Dimensions [mm]

IP - (1 000 pieces)
e.g. 172100.3.15IP

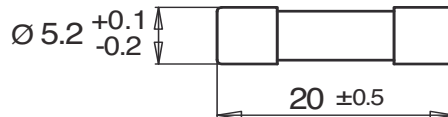

Rated current	Fusing Time Limits									
	1.5I _n		2.1I _n		2.75I _n		4I _n		10I _n	
	Min	Max	Min	Max	Min	Max	Min	Max	Min	Max
32mA - 1.25A	1h	—	—	10m	—	—	40ms	2s	5ms	90ms
1.6A - 10A	1h	—	—	30m	—	—	40ms	2s	5ms	90ms

GZ **Rated Voltage** **Rated Breaking Test** **Class** **Standard(s)**
 [Un] **Voltage** **Capacity** **M** **DIN 41571-2**
 250V_{AC} 250V_{AC} 1.5kA

RoHS

5mmx20mm - Ceramic tube w/ filler, end caps - brass, nickel plated

Rated current I_n [A]	Article Number	Rated breaking current [A]	Voltage drop [mV]	Power dissipation @ 1.5 I_n [W]	Pre-arcing I^2t [A ² s]	Approvals
0.125	172200.0.125	1.5kA @ 250V _{AC}	230	0.1	0.018	
0.160	172200.0.160	1.5kA @ 250V _{AC}	220	0.1	0.036	
0.200	172200.0.200	1.5kA @ 250V _{AC}	190	0.2	0.07	
0.250	172200.0.250	1.5kA @ 250V _{AC}	150	0.2	0.19	
0.315	172200.0.315	1.5kA @ 250V _{AC}	140	0.2	0.35	
0.400	172200.0.400	1.5kA @ 250V _{AC}	130	0.2	0.49	
0.500	172200.0.500	1.5kA @ 250V _{AC}	120	0.2	0.09	
0.630	172200.0.630	1.5kA @ 250V _{AC}	650	0.4	0.6	
0.800	172200.0.800	1.5kA @ 250V _{AC}	500	0.6	1.0	
1	172200.1	1.5kA @ 250V _{AC}	450	0.8	1.5	
1.25	172200.1.25	1.5kA @ 250V _{AC}	400	0.8	3.1	
1.6	172200.1.6	1.5kA @ 250V _{AC}	150	0.8	6.1	
2	172200.2	1.5kA @ 250V _{AC}	130	0.8	5.2	
2.5	172200.2.5	1.5kA @ 250V _{AC}	110	0.9	10	
3.15	172200.3.15	1.5kA @ 250V _{AC}	100	1.0	20	
4	172200.4	1.5kA @ 250V _{AC}	90	1.1	37	
5	172200.5	1.5kA @ 250V _{AC}	90	1.3	72	
6.3	172200.6.3	1.5kA @ 250V _{AC}	90	1.6	130	
8	172200.8	1.5kA @ 250V _{AC}	90	2.0	230	
10	172200.10	1.5kA @ 250V _{AC}	90	2.5	370	

Weight (kg per 100)
0.14
Units per package
10

Time-Current Characteristics

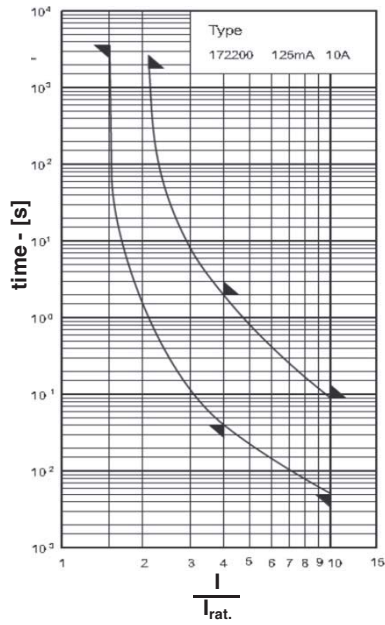



IP - (1 000 pieces)
 e.g. 172200.10IP

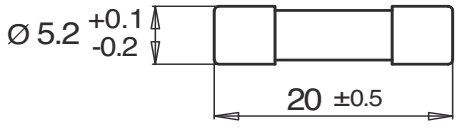

Dimensions [mm]



Rated current	Fusing Time Limits									
	1.5 I_n		2.1 I_n		2.75 I_n		4 I_n		10 I_n	
	Min	Max	Min	Max	Min	Max	Min	Max	Min	Max
125mA - 10A	1h	—	—	30m	—	—	40ms	2s	5ms	90ms

GZ    **Rated Voltage** [Un] **Rated Breaking Test** **Class** **Standard(s)**

250V_{AC} **250V_{AC}** **35A / 10I_{rat}** **T** **IEC 60127-2/3**
EN 60127-2/3
VDE 0820 - 2/3

5mmx20mm - Glass Tube, Contacts - Brass, Nickel Plated

Rated current I _n [A]	Article Number	UL rec	Rated breaking current [A]	Voltage drop [mV]	Power dissipation @ 1.5I _n [W]	Pre-arcing I ² t [A ² s]	Approvals S - Semko V - VDE
0.032	179120.0.032	✓	35A @ 250V _{AC}	3 000	0.2	0.01	S V
0.040	179120.0.040	✓	35A @ 250V _{AC}	2 000	0.2	0.02	S V
0.050	179120.0.050	✓	35A @ 250V _{AC}	1 500	0.2	0.035	S V
0.063	179120.0.063	✓	35A @ 250V _{AC}	1 000	0.2	0.05	S V
0.080	179120.0.080	✓	35A @ 250V _{AC}	800	0.2	0.12	S V
0.100	179120.0.100	✓	35A @ 250V _{AC}	700	0.3	0.16	S V
0.125	179120.0.125	✓	35A @ 250V _{AC}	600	0.3	0.24	S V
0.160	179120.0.160	✓	35A @ 250V _{AC}	600	0.3	0.4	S V
0.200	179120.0.200	✓	35A @ 250V _{AC}	500	0.3	0.7	S V
0.250	179120.0.250	✓	35A @ 250V _{AC}	400	0.3	1.4	S V
0.315	179120.0.315	✓	35A @ 250V _{AC}	140	0.2	0.35	S V
0.400	179120.0.400	✓	35A @ 250V _{AC}	130	0.2	0.49	S V
0.500	179120.0.500	✓	35A @ 250V _{AC}	120	0.2	0.9	S V
0.630	179120.0.630	✓	35A @ 250V _{AC}	110	0.2	1.4	S V
0.700	179120.0.700	✓	35A @ 250V _{AC}	140	0.3	1.6	S V
0.800	179120.0.800	✓	35A @ 250V _{AC}	100	0.3	3.2	S V
1	179120.1	✓	35A @ 250V _{AC}	90	0.3	6.5	S V
1.25	179120.1.25	✓	35A @ 250V _{AC}	80	0.3	5.0	S V
1.4	179120.1.4		35A @ 250V _{AC}	80	0.4	5.2	
1.5	179120.1.5		35A @ 250V _{AC}	80	0.4	8.5	
1.6	179120.1.6	✓	35A @ 250V _{AC}	80	0.4	10	S V
2	179120.2	✓	35A @ 250V _{AC}	80	0.5	20	S V
2.5	179120.2.5	✓	35A @ 250V _{AC}	80	0.6	26	S V
3.15	179120.3.15	✓	35A @ 250V _{AC}	80	0.6	44	S V
3.5	179120.3.5		35A @ 250V _{AC}	80	0.8	50	
4	179120.4	✓	40A @ 250V _{AC}	80	0.8	72	S V
5	179120.5	✓	50A @ 250V _{AC}	80	1.2	130	S V
6.3	179120.6.3	✓	63A @ 250V _{AC}	70	1.3	230	S V
8	179120.8		80A @ 250V _{AC}	70	1.8	240	
10	179120.10		100A @ 250V _{AC}	70	2.4	380	
12.5	179120.12.5		125A @ 250V _{AC}	70	3.0	650	
16	179120.16		160A @ 250V _{AC}	70	3.2	1 300	
20	179120.20		200A @ 250V _{AC}	70	3.5	2 200	

Time-Current Characteristics

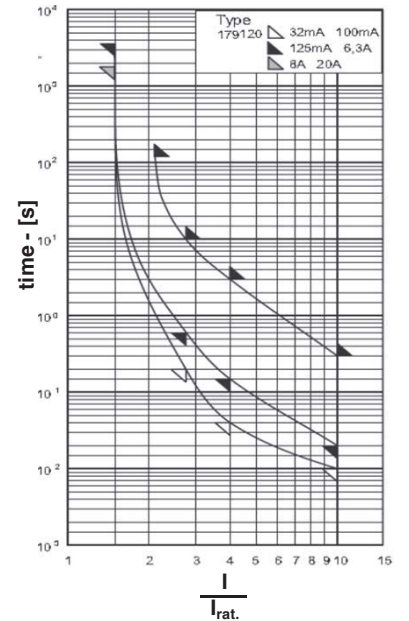

Weight (kg per 100)
0.14
Units per package
10

Dimensions [mm]



FC - 1 000 pieces with color code
 AK - with assembled leaded caps
 IP - (1 000 pieces)
 e.g. 179120.1.25IP

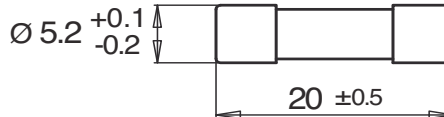

Rated current	Fusing Time Limits									
	1.5I _n		2.1I _n		2.75I _n		4I _n		10I _n	
	Min	Max	Min	Max	Min	Max	Min	Max	Min	Max
32mA - 100mA	1h	—	—	2m	200ms	10s	40ms	3s	10ms	300ms
125mA - 6.3A	1h	—	—	2m	600ms	10s	150ms	3s	20ms	300ms
8A - 20A	30m	—	—	2m	600ms	10s	150ms	3s	20ms	300ms

GZ Rated **Rated Voltage** [Un] **Breaking Test** **Class** **Standard(s)**

250V_{AC} **Voltage** **Capacity** **T** **IEC 60127-2/6**
250V_{AC} **150A** **EN 60127-2/6**
VDE 0820 - 2/6

5mmx20mm - Glass tube, end caps - brass, nickel plated

Rated current I_n [A]	Article Number	Rated breaking current [A]	Voltage drop [mV]	Power dissipation @ 1.5 I_n [W]	Pre-arcing I^2t [A ² s]	Approvals S - Semko V - VDE
0.032	179150.0.032	150A @ 250V _{AC}	3 000	0.2	0.01	
0.040	179150.0.040	150A @ 250V _{AC}	2 000	0.2	0.02	
0.050	179150.0.050	150A @ 250V _{AC}	1 500	0.2	0.035	
0.063	179150.0.063	150A @ 250V _{AC}	1 000	0.2	0.05	
0.080	179150.0.080	150A @ 250V _{AC}	800	0.2	0.12	
0.100	179150.0.100	150A @ 250V _{AC}	700	0.3	0.16	
0.125	179150.0.125	150A @ 250V _{AC}	600	0.3	0.24	
0.160	179150.0.160	150A @ 250V _{AC}	600	0.3	0.4	
0.200	179150.0.200	150A @ 250V _{AC}	500	0.3	0.7	
0.250	179150.0.250	150A @ 250V _{AC}	400	0.3	1.4	
0.315	179150.0.315	150A @ 250V _{AC}	140	0.2	0.35	
0.400	179150.0.400	150A @ 250V _{AC}	130	0.2	0.49	
0.500	179150.0.500	150A @ 250V _{AC}	120	0.2	0.9	S V
0.630	179150.0.630	150A @ 250V _{AC}	110	0.2	1.4	S V
0.800	179150.0.800	150A @ 250V _{AC}	100	0.3	3.2	S V
1	179150.1	150A @ 250V _{AC}	90	0.3	6.5	S V
1.25	179150.1.25	150A @ 250V _{AC}	80	0.3	5.0	S V
1.6	179150.1.6	150A @ 250V _{AC}	80	0.4	10	S V
2	179150.2	150A @ 250V _{AC}	80	0.5	20	S V
2.5	179150.2.5	150A @ 250V _{AC}	80	0.6	26	S V
3.15	179150.3.15	150A @ 250V _{AC}	80	0.6	44	S V
4	179150.4	150A @ 250V _{AC}	80	0.8	72	S V
5	179150.5	150A @ 250V _{AC}	80	1.2	130	
6.3	179150.6.3	150A @ 250V _{AC}	70	1.3	230	
8	179150.8	150A @ 250V _{AC}	70	1.8	240	
10	179150.10	150A @ 250V _{AC}	70	2.4	380	

Time-Current Characteristics

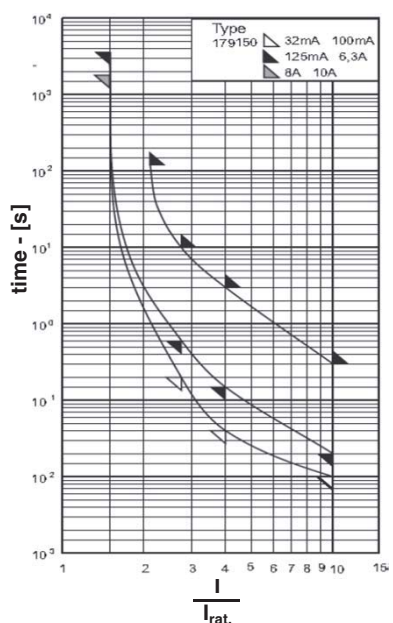

Weight (kg per 100)
0.14
Units per Package
10



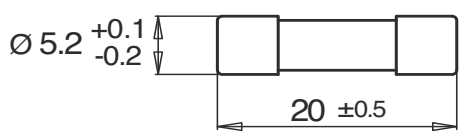

IP - (1 000 pieces)
 e.g. 179150.0.63IP

Dimensions [mm]



Rated current	Fusing Time Limits									
	1.5 I_n		2.1 I_n		2.75 I_n		4 I_n		10 I_n	
	Min	Max	Min	Max	Min	Max	Min	Max	Min	Max
32mA - 100mA	1h	—	—	2m	200ms	10s	40ms	3s	10ms	300ms
125mA - 6.3A	1h	—	—	2m	600ms	10s	150ms	3s	20ms	300ms
8A - 10A	30m	—	—	2m	600ms	10s	150ms	3s	20ms	300ms

GZ    **Rated Voltage** [Un] 250V_{AC} **Rated Breaking Test** Voltage 250V_{AC} Capacity 1.5kA **Class** T **Standard(s)** IEC 60127-2/5 EN 60127-2/5 VDE 0820 - 2/5

5mmx20mm - Ceramic tube w/ filler, end caps - brass, nickel plated

Rated current I _n [A]	Article Number	UL rec	Rated breaking current [A]	Voltage drop [mV]	Power dissipation @ 1.5I _n [W]	Pre-arcing I ² t [A ² s]	Approvals S - Semko V - VDE
Without Filling							
0.050	179200.0.050	✓	1.5kA @ 250V _{AC} ¹	1 500	0.2	0.02	
0.063	179200.0.063	✓	1.5kA @ 250V _{AC} ¹	1 000	0.2	0.05	
With Filling							
0.080	179200.0.080	✓	1.5kA @ 250V _{AC} ¹	2 800	0.6	0.02	
0.100	179200.0.100	✓	1.5kA @ 250V _{AC} ¹	2 300	0.6	0.02	
0.125	179200.0.125	✓	1.5kA @ 250V _{AC} ¹	2 200	0.8	0.045	
0.160	179200.0.160	✓	1.5kA @ 250V _{AC} ¹	2 100	0.9	0.08	
0.200	179200.0.200	✓	1.5kA @ 250V _{AC} ¹	1 800	0.9	0.14	
0.250	179200.0.250	✓	1.5kA @ 250V _{AC} ¹	1 500	1.0	0.25	
0.315	179200.0.315	✓	1.5kA @ 250V _{AC} ¹	1 000	1.0	0.45	
0.400	179200.0.400	✓	1.5kA @ 250V _{AC} ¹	850	1.0	0.8	
0.500	179200.0.500	✓	1.5kA @ 250V _{AC} ¹	350	0.4	0.35	
0.630	179200.0.630	✓	1.5kA @ 250V _{AC} ¹	300	0.4	0.6	
0.800	179200.0.800	✓	1.5kA @ 250V _{AC} ¹	300	0.6	1.0	
1	179200.1 ²	✓	1.5kA @ 250V _{AC} ¹	250	0.8	1.5	S V
1.25	179200.1.25 ²	✓	1.5kA @ 250V _{AC} ¹	200	0.8	3.1	S V
1.6	179200.1.6 ²	✓	1.5kA @ 250V _{AC} ¹	150	0.8	6.1	S V
2	179200.2 ²	✓	1.5kA @ 250V _{AC} ¹	130	0.8	5.2	S V
2.5	179200.2.5 ²	✓	1.5kA @ 250V _{AC} ¹	110	0.9	10	S V
3.15	179200.3.15 ²	✓	1.5kA @ 250V _{AC} ¹	100	1.0	20	S V
4	179200.4 ²	✓	1.5kA @ 250V _{AC} ¹	90	1.1	37	S V
5	179200.5	✓	1.5kA @ 250V _{AC} ¹	90	1.3	72	S V
6.3	179200.6.3	✓	1.5kA @ 250V _{AC} ¹	90	1.6	130	S V
8	179200.8	✓	1.5kA @ 250V _{AC} ¹	90	2.0	230	
10	179200.10	✓	1.5kA @ 250V _{AC} ¹	90	2.5	370	
12.5	179200.12.5		1.5kA @ 250V _{AC} ¹	70	3.1	630	
16	179200.16		1.5kA @ 250V _{AC} ¹	70	3.9	1 500	

Weight (kg per 100)	¹⁾ cos φ = 0.7 - 0.8
0.14	²⁾ UL Rec. 1.5kA@300VDC, L/R = resistive - 1A - 10A
Units per package	
10	



Dimensions [mm]

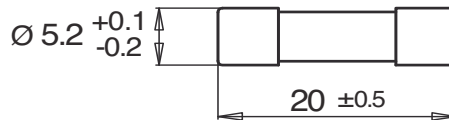

FC - 1 000 pieces with color code
 AK - with assembled leaded caps
 IP - (1 000 pieces)
 e.g. 179200.3.15IP

Time-Current Characteristics

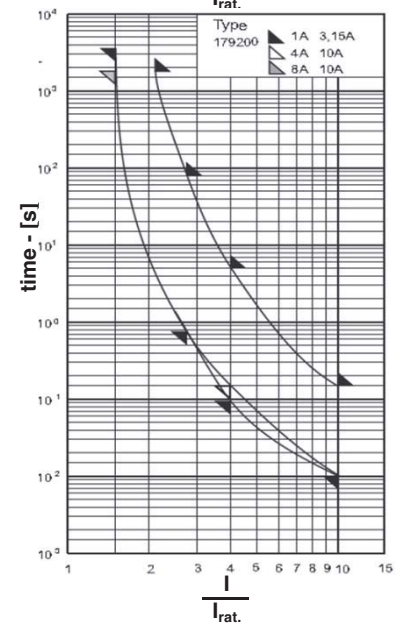
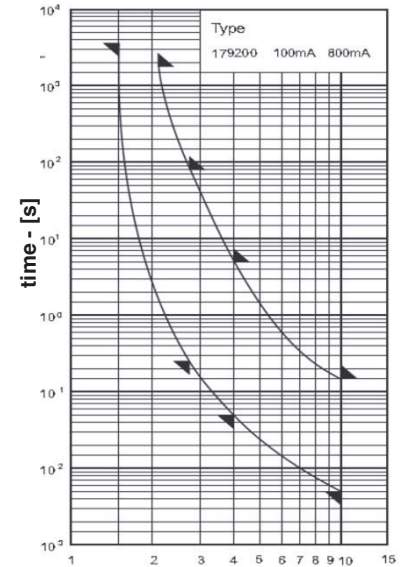

Rated current	Fusing Time Limits									
	1.5I _n		2.1I _n		2.75I _n		4I _n		10I _n	
	Min	Max	Min	Max	Min	Max	Min	Max	Min	Max
50mA - 800mA	1h	—	—	30m	250ms	80s	50ms	5s	5s	150ms
1A - 3.15A	1h	—	—	30m	750ms	80s	95ms	5s	10ms	150ms
4A - 6.3A	1h	—	—	30m	750ms	80s	150ms	5s	10ms	150ms
8A - 16A	30m	—	—	30m	750ms	80s	150ms	5s	10ms	150ms

GSMZ



E167295

Rated Voltage

[Un]
250V_{AC}

Rated Breaking Test

Voltage Capacity
250V_{AC} 1.5kA

Class

T



Standard(s)

IEC 60127-2/5
EN 60127-2/5
VDE 0820 - 2/5

5mmx20mm - Ceramic tube w/ filler, end caps - brass, gold plated

Rated current I_n [A]	Article Number	UL rec	Rated breaking current [A]	Voltage drop [mV]	Power dissipation @ 1.5 I_n [W]	Pre-arcing I^2t [A ² s]
1	179200.1SMD	✓	1.5kA @ 250V _{AC} ¹	250	0.8	1.5
1.25	179200.1.25SMD	✓	1.5kA @ 250V _{AC} ¹	200	0.8	3.1
1.6	179200.1.6SMD	✓	1.5kA @ 250V _{AC} ¹	150	0.8	6.1
2	179200.2SMD	✓	1.5kA @ 250V _{AC} ¹	130	0.8	5.2
2.5	179200.2.5SMD	✓	1.5kA @ 250V _{AC} ¹	110	0.9	10
3.15	179200.3.15SMD	✓	1.5kA @ 250V _{AC} ¹	100	1.0	20
4	179200.4SMD	✓	1.5kA @ 250V _{AC} ¹	90	1.1	37
5	179200.5SMD	✓	1.5kA @ 250V _{AC} ¹	90	1.3	72
6.3	179200.6.3SMD	✓	1.5kA @ 250V _{AC} ¹	90	1.6	130

Weight (kg per 100) ¹⁾ cos φ = 0.7 - 0.8

Units per package

Time-Current Characteristics

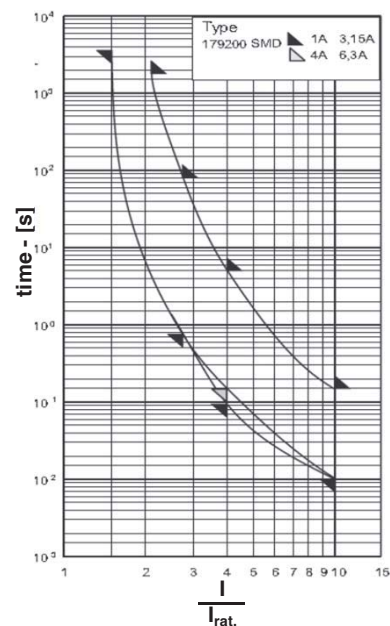

Further cylindrical SMD fuse versions on request



Dimensions [mm]

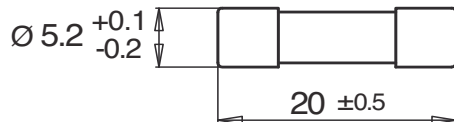

Rated current	Fusing Time Limits									
	1.5 I_n		2.1 I_n		2.75 I_n		4 I_n		10 I_n	
	Min	Max	Min	Max	Min	Max	Min	Max	Min	Max
1A - 3.15A	1h	—	—	30m	750ms	80s	95ms	5s	10ms	150ms
4A - 6.3A	1h	—	—	30m	750ms	80s	150ms	5s	10ms	150ms

SIBA LLC

29 Fairfield Place
West Caldwell, New Jersey 07006

Phone 1-973-575-7422
Fax 1-973-575-5858

portal: www.siballc.net
e-mail: info@sibafuse.com

GZ		Rated Voltage	Rated Breaking Test	Class	Standard(s)
		[Un] 250V _{AC}	Voltage 250V _{AC} Capacity 300A	T	DIN 41571-3

5mmx20mm - Glass tube w/ filler, end caps - brass, nickel plated

Rated current I_n [A]	Article Number	Rated breaking current [A]	Voltage drop [mV]	Power dissipation @ 1.5 I_n [W]	Pre-arcing I^2t [A ² s]	Approvals
1.6	173100.1.6	300A @ 250V _{AC}	200 ¹⁾	0.8	16	
2	173100.2	300A @ 250V _{AC}	190 ¹⁾	0.9	26	
2.5	173100.2.5	300A @ 250V _{AC}	180 ¹⁾	1.1	45	
3.15	173100.3.15	300A @ 250V _{AC}	140	1.3	72	
4	173100.4	300A @ 250V _{AC}	135	1.4	130	
5	173100.5	300A @ 250V _{AC}	130	1.2	150	
6.3	173100.6.3	300A @ 250V _{AC}	125	1.3	240	
8	173100.8	300A @ 250V _{AC}	120	1.6	390	
10	173100.10	300A @ 250V _{AC}	115	1.9	620	
12.5	173100.12.5	300A @ 250V _{AC}	100	2.8	1 150	
15	173100.15	300A @ 250V _{AC}	80	3.3	1 800	
16	173100.16	300A @ 250V _{AC}	80	3.8	1 800	

Weight (kg per 100)
0.13
Units per package
100

IP - (1 000 pieces)
e.g. 173100.1.6IP

¹⁾ Maximum according to EN 60127-2/5

Time-Current Characteristics

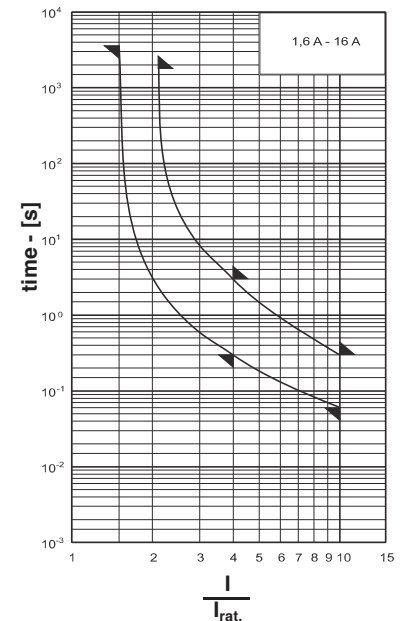
Dimensions
[mm]

Rated current	Fusing Time Limits									
	1.5 I_n		2.1 I_n		2.75 I_n		4 I_n		10 I_n	
	Min	Max	Min	Max	Min	Max	Min	Max	Min	Max
1.6A - 10A	1h	—	—	30m	—	—	300ms	3s	60ms	300ms

GZ **Rated Voltage** [Un] **Rated Breaking Test** **Class** **Standard(s)**

E167295 **250V_{AC}** **250V_{AC}** **35A / 100A** **T/D** **UL 248-14**
5mmx20mm - Glass tube, end caps - brass, nickel plated **CSA C22.2 - No 248.14**

Rated current I _n [A]	Article Number	UL listed	Rated breaking Current [A]	Voltage Drop [mV]	Power Dissipation @ 1.0I _n [W]	Pre-arcing I ² t [A ² s]	Approvals
0.080	179500.0.080	✓	35A @ 250V _{AC} ¹	2 800	0.3	0.024	
0.100	179500.0.100	✓	35A @ 250V _{AC} ¹	2 400	0.3	0.053	
0.125	179500.0.125	✓	35A @ 250V _{AC} ¹	2 100	0.3	0.08	
0.150	179500.0.150	✓	35A @ 250V _{AC} ¹	1 800	0.3	0.13	
0.200	179500.0.200	✓	35A @ 250V _{AC} ¹	1 300	0.3	0.24	
0.250	179500.0.250	✓	35A @ 250V _{AC} ¹	1 100	0.3	0.42	
0.300	179500.0.300	✓	35A @ 250V _{AC} ¹	1 050	0.4	0.8	
0.375	179500.0.375	✓	35A @ 250V _{AC} ¹	900	0.4	1.5	
0.400	179500.0.400	✓	35A @ 250V _{AC} ¹	850	0.4	1.6	
0.500	179500.0.500	✓	35A @ 250V _{AC} ¹	650	0.4	2.0	
0.630	179500.0.630	✓	35A @ 250V _{AC} ¹	550	0.4	3.1	
0.700	179500.0.700	✓	35A @ 250V _{AC} ¹	500	0.4	4.5	
0.750	179500.0.750	✓	35A @ 250V _{AC} ¹	450	0.4	5.5	
0.800	179500.0.800	✓	35A @ 250V _{AC} ¹	400	0.4	6.4	
1	179500.1	✓	35A @ 250V _{AC} ¹	350	0.4	12	
1.25	179500.1.25	✓	100A @ 250V _{AC} ²	300	0.4	19	
1.5	179500.1.5	✓	100A @ 250V _{AC} ²	280	0.5	25	
1.6	179500.1.6	✓	100A @ 250V _{AC} ²	270	0.5	32	
2	179500.2	✓	100A @ 250V _{AC} ²	235	0.5	55	
2.5	179500.2.5	✓	100A @ 250V _{AC} ²	215	0.6	90	
3	179500.3	✓	100A @ 250V _{AC} ²	200	0.6	160	

Time-Current Characteristics

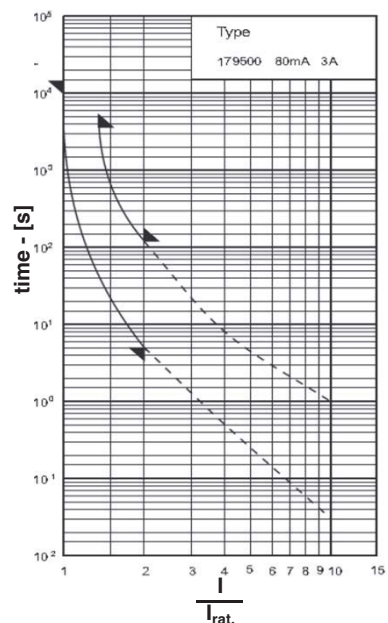

Weight (kg per 100)
0.1
Units per package
10

¹)10kA @ 125V_{AC}, 35A @ 250V_{AC} - cosφ = 0.7 -0.8
²)10kA @ 125V_{AC}, 100A @ 250V_{AC} - cosφ = 0.7 -0.8

IP - (1 000 pieces)
 e.g. 179500.1.6IP



Dimensions [mm]



Rated current	Fusing Time Limits									
	1.0I _n		1.35I _n		2.0I _n					
	Min	Max	Min	Max	Min	Max	Min	Max	Min	Max
80mA - 3A	4h	—	—	1h	5s	120s	—	—	—	—

GZ Rated Voltage Rated Breaking Test Class Standard(s)

[Un] Voltage Capacity TT Special Type

250V_{AC} 250V_{AC} 35A / 10 I_{rat}

5mmx20mm - Glass tube, end caps - brass, nickel plated

Rated current I _n [A]	Article Number	Rated breaking current [A]	Voltage drop [mV]	Power dissipation @ 1.0I _n [W]	Pre-arcing I ² t [A ² s]	Approvals
0.400	190000.0.400	35A @ 250V _{AC}	500	0.3	2.5	
0.500	190000.0.500	35A @ 250V _{AC}	450	0.3	4.6	
0.630	190000.0.630	35A @ 250V _{AC}	400	0.3	10	
0.800	190000.0.800	35A @ 250V _{AC}	300	0.4	15	
1	190000.1	35A @ 250V _{AC}	250	0.4	26	
1.25	190000.1.25	35A @ 250V _{AC}	200	0.4	37	
1.6	190000.1.6	35A @ 250V _{AC}	200	0.5	45	
2	190000.2	35A @ 250V _{AC}	200	0.6	72	
2.5	190000.2.5	35A @ 250V _{AC}	150	0.6	130	
3.15	190000.3.15	35A @ 250V _{AC}	150	0.6	230	
4	190000.4	40A @ 250V _{AC}	100	0.8	370	

Weight (kg per 100)
0.1
Units per package
10

IP - (1 000 pieces)
e.g. 190000.2IP

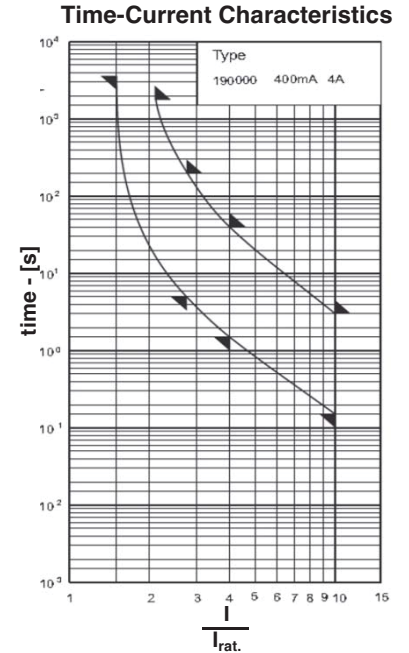

Dimensions [mm]



Rated current	Fusing Time Limits									
	1.5I _n		2.1I _n		2.75I _n		4I _n		10I _n	
	Min	Max	Min	Max	Min	Max	Min	Max	Min	Max
400mA - 4A	1h	—	—	30m	5s	200s	1.5s	40s	150ms	3s

GZM



Rated Voltage

[Un]
60V_{AC}

Rated Breaking Test

Voltage Capacity
60V_{AC} 1.5kA

Class



Standard(s)

DIN 41572

10mmx51mm - Glass tube, end caps - brass, nickel plated

Rated current I_n [A]	Article Number	Rated breaking current [A]	Voltage drop [mV]	Power dissipation [W]	Pre-arcing i^2t [A ² s]	Approvals
0.500	7001908.0.500	1.5kA @ 60V _{AC}	1 500		0.16	
0.800	7001908.0.800	1.5kA @ 60V _{AC}	1 200		0.8	
1	7001908.1	1.5kA @ 60V _{AC}	1 000		0.64	
1.6	7001908.1.6	1.5kA @ 60V _{AC}	1 120		2.6	
2	7001908.2	1.5kA @ 60V _{AC}	1 200		4.9	
2.5	7001908.2.5	1.5kA @ 60V _{AC}	1 000		10	
3	7001908.3	1.5kA @ 60V _{AC}	900		19	
4	7001908.4	1.5kA @ 60V _{AC}	800		41	
6	7001908.6	1.5kA @ 60V _{AC}	600		140	

Weight (kg per 100)
Units per package

Time-Current Characteristics

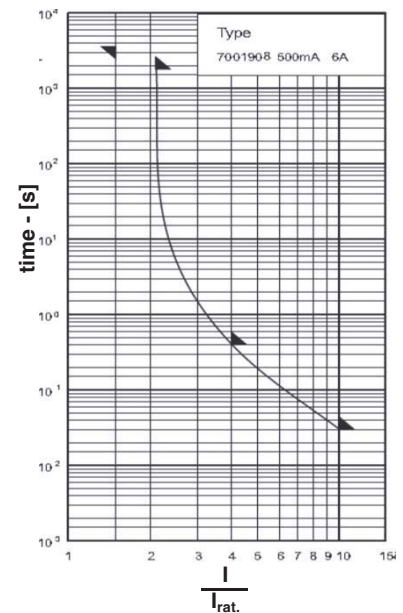

Dimensions [mm]

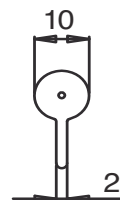
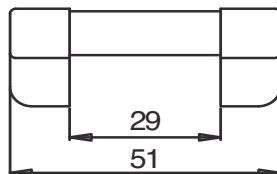

Rated current	Fusing Time Limits									
	1.5I _n		2.1I _n		2.75I _n		5I _n		10I _n	
	Min	Max	Min	Max	Min	Max	Min	Max	Min	Max
500mA - 6A	1h	—	—	30m	—	—	—	400ms	—	30ms

GS Rated Voltage [Un] 250V_{AC} Rated Breaking Test Voltage 250V_{AC} Capacity 50A / 80A Class F & M Standard(s) Special Type

RoHS

5mmx25mm - Glass tube w/ filler, end caps - brass, nickel plated

Rated current I _n [A]	F Article Number	M Article Number	Rated breaking current [A]	Approvals
Without filling				
0.032	171525.0.032	172525.0.032	50A @ 250V _{AC}	
0.050	171525.0.050	172525.0.050	50A @ 250V _{AC}	
0.063	171525.0.063	172525.0.063	50A @ 250V _{AC}	
0.080	171525.0.080	172525.0.080	50A @ 250V _{AC}	
0.100	171525.0.100	172525.0.100	50A @ 250V _{AC}	
0.125	171525.0.125	172525.0.125	50A @ 250V _{AC}	
0.160	171525.0.160	172525.0.160	50A @ 250V _{AC}	
0.200	171525.0.200	172525.0.200	50A @ 250V _{AC}	
0.250	171525.0.250	172525.0.250	50A @ 250V _{AC}	
0.315	171525.0.315	172525.0.315	50A @ 250V _{AC}	
0.400	171525.0.400	172525.0.400	50A @ 250V _{AC}	
0.500	171525.0.500	172525.0.500	50A @ 250V _{AC}	
0.630	171525.0.630	172525.0.630	50A @ 250V _{AC}	
0.800	171525.0.800	172525.0.800	50A @ 250V _{AC}	
1	171525.1	172525.1	50A @ 250V _{AC}	
1.25	171525.1.25	172525.1.25	50A @ 250V _{AC}	
With filling				
1.6	171525.1.6	172525.1.6	80A @ 250V _{AC}	
2	171525.2	172525.2	80A @ 250V _{AC}	
2.5	171525.2.5	172525.2.5	80A @ 250V _{AC}	
3.15	171525.3.15	172525.3.15	80A @ 250V _{AC}	
4	171525.4	172525.4	80A @ 250V _{AC}	
5	171525.5	172525.5	80A @ 250V _{AC}	
6.3	171525.6.3	172525.6.3	80A @ 250V _{AC}	
8	171525.8	172525.8	80A @ 250V _{AC}	
10	171525.10	172525.10	80A @ 250V _{AC}	

Weight (kg per 100)	
0.12	0.15
Units per package	
10	



Dimensions [mm]

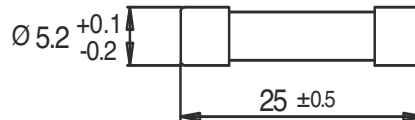

	Rated current	Fusing Time Limits									
		1.5I _n		2.1I _n		2.75I _n		4I _n		10I _n	
		Min	Max	Min	Max	Min	Max	Min	Max	Min	Max
171525	32mA - 10A	1h	—	—	—	—	100s	20s	600ms	—	80ms
172525	32mA - 10A	1h	—	—	—	100s	20s	20ms	2s	5ms	100ms

Time-Current Characteristics

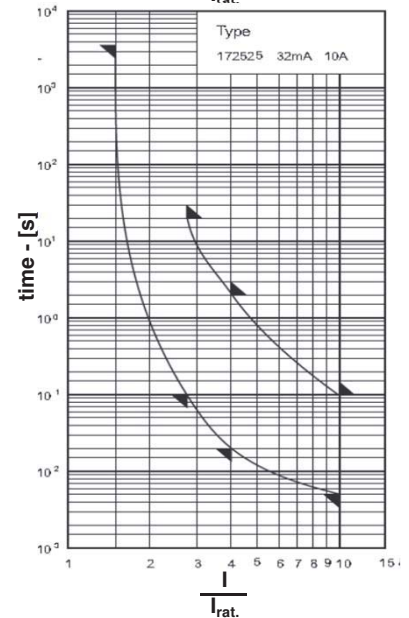
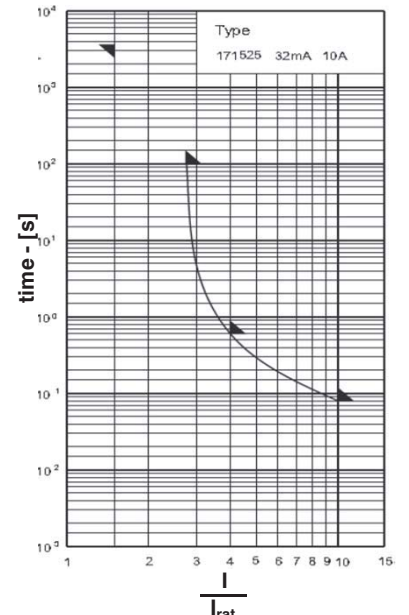

GZ **Rated Voltage** **Rated Breaking Test** **Class** **Standard(s)**
RoHS **[Un]** **Voltage** **Capacity** **F** **DIN 41576-1**
 250V_{AC} 250V_{AC} 1.5kA

5mmx25mm - Ceramic tube w/ indicator, w/ filler, contacts - brass, nickel plated

Rated current I_n [A]	Article Number	Rated breaking current [A]	Voltage drop [mV]	Power dissipation @ 1.5 I_n [W]	Pre-arcing I^2t [A ² s]	Color code
1.6	171526.1.6	1.5kA @ 250V _{AC}	640	0.9	2.3	Orange
2	171526.2	1.5kA @ 250V _{AC}	420	1.1	2.4	Blue
2.5	171526.2.5	1.5kA @ 250V _{AC}	320	1.2	4	Yellow
3.15	171526.3.15	1.5kA @ 250V _{AC}	250	1.4	6.5	Black
4	171526.4	1.5kA @ 250V _{AC}	200	1.7	16	Brown
5	171526.5	1.5kA @ 250V _{AC}	180	2.1	33	White
6.3	171526.6.3	1.5kA @ 250V _{AC}	170	2.5	63	Green
8	171526.8	1.5kA @ 250V _{AC}	150	3.0	100	Grey
10	171526.10	1.5kA @ 250V _{AC}	120	3.3	200	Red

Weight (kg per 100)
0.13
Units per Package
10

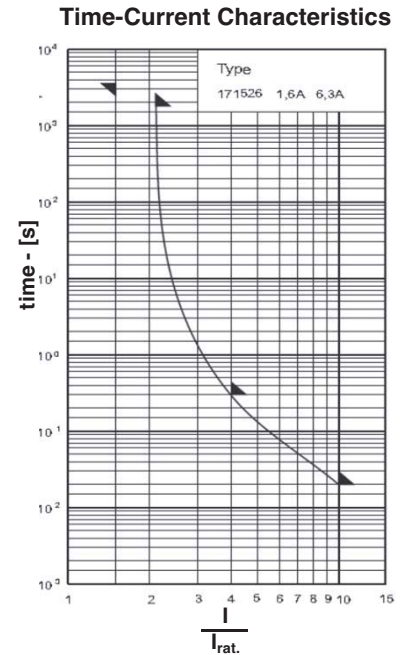

Dimensions [mm]

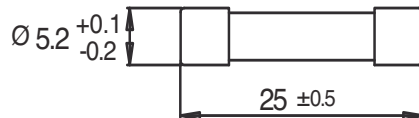

Rated current	Fusing Time Limits									
	1.5 I_n		2.1 I_n		2.75 I_n		4 I_n		10 I_n	
	Min	Max	Min	Max	Min	Max	Min	Max	Min	Max
1.6A - 6.3A	1h	—	—	30m	—	—	—	300ms	—	20ms

GZ KM **Rated Voltage** **Rated Breaking Test** **Class** **Standard(s)**

RoHS

[Un] Voltage Capacity M DIN 41576-2

250V_{AC} 250V_{AC} 80A / 1.5kA

5mmx25mm - Ceramic tube w/ indicator, w/ filler, end caps - brass, nickel plated

Rated current I _n [A]	Article Number	Rated breaking current [A]	Voltage drop [mV]	Power dissipation @ 1.5I _n [W]	Pre-arcing I ² t [A ² s]	Color code
Without filler						
0.050	172526.0.050	80A @ 250V _{AC}	520	0.1	0.005	White
0.063	172526.0.063	80A @ 250V _{AC}	520	0.1	0.007	Green
0.080	172526.0.080	80A @ 250V _{AC}	520	0.1	0.009	Grey
0.100	172526.0.100	80A @ 250V _{AC}	500	0.1	0.022	Red
0.125	172526.0.125	80A @ 250V _{AC}	500	0.1	0.041	Violet
0.160	172526.0.160	80A @ 250V _{AC}	400	0.1	0.1	Orange
0.200	172526.0.200	80A @ 250V _{AC}	400	0.2	0.2	Blue
0.250	172526.0.250	1.5kA @ 250V _{AC}	375	0.2	0.22	Yellow
0.315	172526.0.315	1.5kA @ 250V _{AC}	410	0.2	0.31	Black
0.400	172526.0.400	1.5kA @ 250V _{AC}	280	0.2	0.56	Brown
0.500	172526.0.500	1.5kA @ 250V _{AC}	250	0.2	1.1	White
0.630	172526.0.630	1.5kA @ 250V _{AC}	220	0.2	0.7	Green
0.800	172526.0.800	1.5kA @ 250V _{AC}	400	0.2	1.6	Grey
1	172526.1	1.5kA @ 250V _{AC}	350	0.2	3.5	Red
1.25	172526.1.25	1.5kA @ 250V _{AC}	315	0.4	5.5	Violet
With filler						
1.6	172526.1.6	1.5kA @ 250V _{AC}	480	0.6	5.6	Orange
2	172526.2	1.5kA @ 250V _{AC}	360	0.7	9.6	Blue
2.5	172526.2.5	1.5kA @ 250V _{AC}	300	0.9	15	Yellow
3.15	172526.3.15	1.5kA @ 250V _{AC}	250	1.1	24	Black
4	172526.4	1.5kA @ 250V _{AC}	180	1.3	40	Brown
5	172526.5	1.5kA @ 250V _{AC}	180	1.5	87	White
6.3	172526.6.3	1.5kA @ 250V _{AC}	160	1.8	170	Green
8	172526.8	1.5kA @ 250V _{AC}	150	3	190	Grey
10	172526.10	1.5kA @ 250V _{AC}	150	3.2	370	Red

Weight (kg per 100)
0.15
Units per package
10



Dimensions [mm]

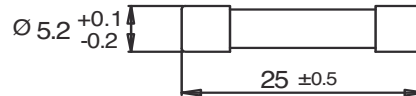

Rated current	Fusing Time Limits									
	1.5I _n		2.1I _n		2.75I _n		5I _n		10I _n	
	Min	Max	Min	Max	Min	Max	Min	Max	Min	Max
80mA - 100mA	1h	—	—	2m	—	—	40ms	500ms	5ms	30ms
125mA - 1.25A	1h	—	—	3m	—	—	60ms	2s	5ms	70ms
1.6A - 6.3A	1h	—	—	30m	—	—	60ms	2s	5ms	70ms

Time-Current Characteristics

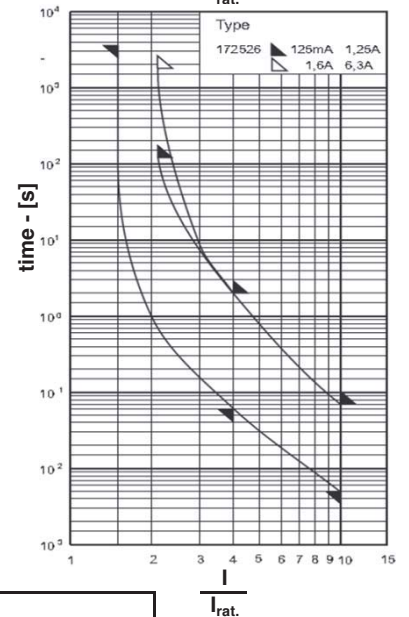
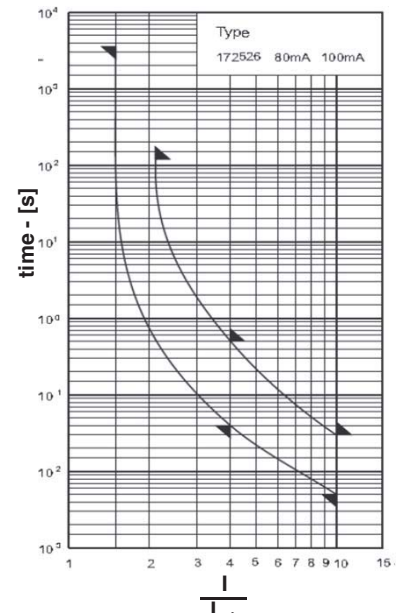

GZKM



Rated Voltage

[Un]
450V_{AC}
250V_{DC}

Rated Breaking Test

Voltage Capacity
500V_{AC} 70kA
250V_{DC} 10kA

Class

F



Standard(s)

VG88851

5mmx25mm - Ceramic tube w/ indicator, w/ filler, end caps - brass, nickel plated

Rated current I_n [A]	Article Number	Rated breaking current [A]	Voltage drop [mV]	Power dissipation @ 1.5 I_n [W]	Pre-arcing i^2t [A ² s]	Color code
0.250	7008913.0.250	70kA @ 500V _{AC} ¹	950	0.3	0.05	Yellow
0.315	7008913.0.315	70kA @ 500V _{AC} ¹	900	0.5	0.05	Black
0.400	7008913.0.400	70kA @ 500V _{AC} ¹	800	0.5	0.15	Brown
0.500	7008913.0.500	70kA @ 500V _{AC} ¹	700	0.6	0.15	White
0.800	7008913.0.800	70kA @ 500V _{AC} ¹	300	0.3	0.25	Grey
1	7008913.1	70kA @ 500V _{AC} ¹	250	0.3	0.5	Red
1.25	7008913.1.25	70kA @ 500V _{AC} ¹	400	0.4	1.1	Violet
1.6	7008913.1.6	70kA @ 500V _{AC} ¹	400	0.9	2.3	Orange
2	7008913.2	70kA @ 500V _{AC} ¹	350	1.1	2.4	Blue
2.5	7008913.2.5	70kA @ 500V _{AC} ¹	300	1.2	4	Yellow
3.15	7008913.3.15	70kA @ 500V _{AC} ¹	300	1.4	6.5	Black
4	7008913.4	70kA @ 500V _{AC} ¹	200	1.7	16	Brown
5	7008913.5	70kA @ 500V _{AC} ¹	200	2.1	33	White
6.3	7008913.6.3	70kA @ 500V _{AC} ¹	150	2.5	63	Green
8	7008913.8	70kA @ 500V _{AC} ¹	190	6	13	Grey
10	7008913.10	70kA @ 500V _{AC} ¹	150	5	32	Red
Weight (kg per 100)		1)10kA @ 250V _{DC}				
0.13						
Units per package						
10						

Time-Current Characteristics

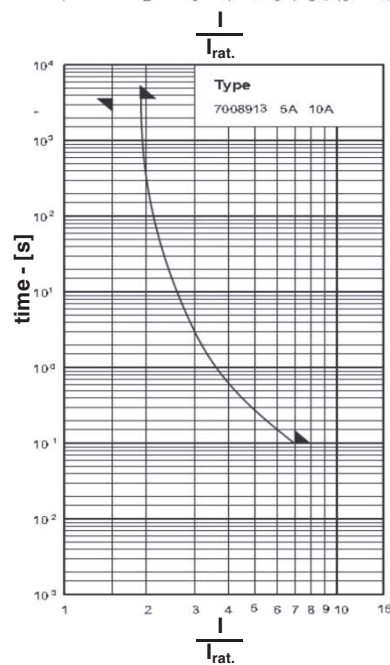
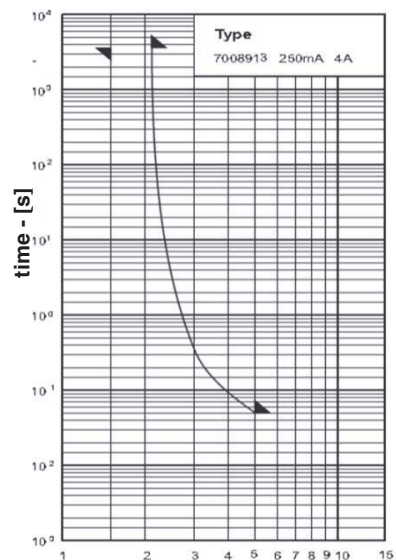

Dimensions [mm]

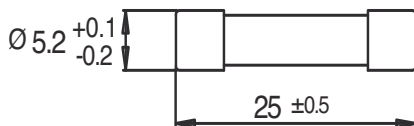

Rated current	Fusing Time Limits									
	1.5 I_n		1.9 I_n		2.1 I_n		5 I_n		7 I_n	
	Min	Max	Min	Max	Min	Max	Min	Max	Min	Max
500mA - 4A	1h	—	—	—	—	—	1h	—	50ms	—
5A - 10A	1h	—	—	1h	—	—	—	—	—	100ms

GZKM Rated Voltage Rated Breaking Test Class Standard(s)

RoHS

[Un] Voltage Capacity M DIN 41577 T.2

250V_{AC} 250V_{AC} 80A / 1.5kA

5mmx"L"mm - Ceramic tube w/ indicator, w/ filler(≥ 250mA), end caps- brass, nickel plated

Rated current <i>I_n</i> [A]	Article Number	Rated breaking current [A]	Voltage drop [mV]	Power dissipation @ 1.5 <i>I_n</i> [mw]	Pre-arcing <i>I</i> ² <i>t</i> [A ² s]	Length "L" [mm]
0.080	7001607.0.080	80A @ 250V _{AC}	520	0.1	0.017	25
0.100	7001607.0.100	80A @ 250V _{AC}	500	0.1	0.022	
0.125	7001607.0.125	80A @ 250V _{AC}	500	0.1	0.041	
0.160	7001607.0.160	80A @ 250V _{AC}	400	0.1	0.1	
0.200	7001607.0.200	80A @ 250V _{AC}	400	0.2	0.2	
0.250	7001707.0.250	1.5kA @ 250V _{AC}	500	0.2	0.22	
0.315	7001707.0.315	1.5kA @ 250V _{AC}	470	0.2	0.31	
0.400	7001707.0.400	1.5kA @ 250V _{AC}	400	0.2	0.56	
0.500	7001707.0.500	1.5kA @ 250V _{AC}	400	0.2	1.1	
0.630	7001707.0.630	1.5kA @ 250V _{AC}	380	0.2	0.7	
0.8	7001407.0.800	1.5kA @ 250V _{AC}	400	0.3	1.6	20
1	7001407.1	1.5kA @ 250V _{AC}	350	0.3	3.5	
1.25	7001407.1.25	1.5kA @ 250V _{AC}	310	0.3	5.5	
1.6	7001407.1.6	1.5kA @ 250V _{AC}	480	1.0	5.6	
2	7001407.2	1.5kA @ 250V _{AC}	360	1.0	9.6	
2.5	7001407.2.5	1.5kA @ 250V _{AC}	300	1.1	15	
3.15	7001407.3.15	1.5kA @ 250V _{AC}	250	1.2	24	
4	7001407.4	1.5kA @ 250V _{AC}	180	1.3	40	
6.3	7001205.6.3	1.5kA @ 250V _{AC}	160	1.8	170	

Weight (kg per 100)
0.15
Units per package
10

Time-Current Characteristics

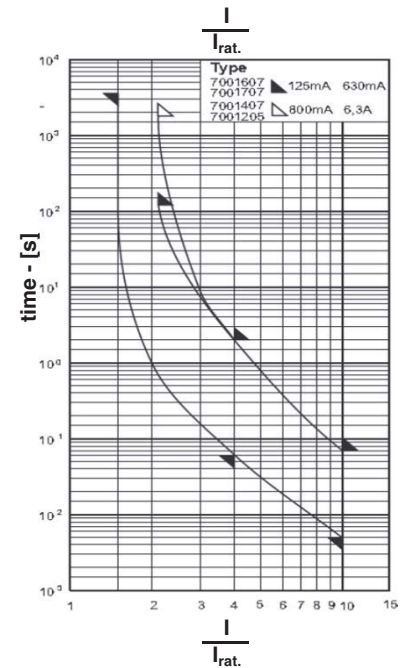
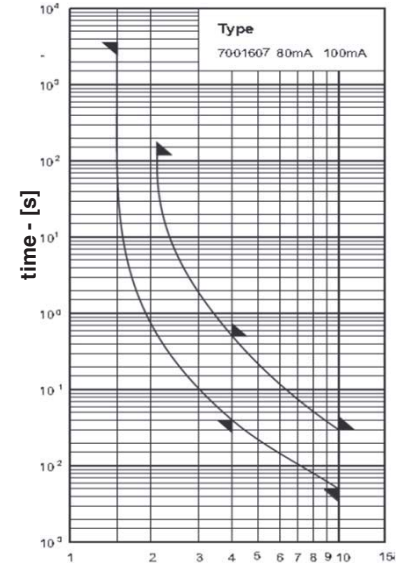

Dimensions [mm]

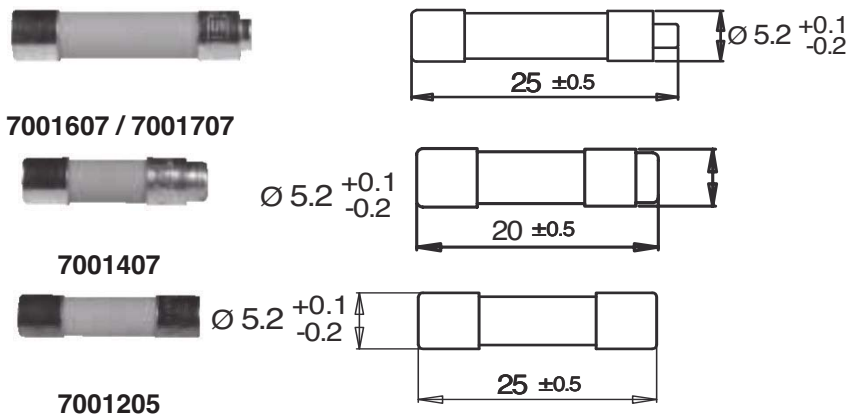

Rated current	Fusing Time Limits									
	1.5 <i>I_n</i>		2.1 <i>I_n</i>		2.75 <i>I_n</i>		4 <i>I_n</i>		10 <i>I_n</i>	
	Min	Max	Min	Max	Min	Max	Min	Max	Min	Max
80mA - 100mA	1h	—	—	2m	—	—	40ms	500ms	5ms	30ms
125mA - 630mA	1h	—	—	2m	—	—	60ms	2s	5ms	70ms
800mA - 6.3A	1h	—	—	30m	—	—	60ms	2s	5ms	70ms

GZ

Rated Voltage

Rated Breaking Test

Class

Standard(s)



[Un]
500V_{AC}

Voltage
500V_{AC}

Capacity
50A / 80A



F/M

Special Type

5mmx30mm - Glass tube w/ filler, end caps - brass, nickel plated

Rated current I_n [A]	F		Rated breaking current [A]
	Article Number	Article Number	
Without filling			
0.032	171530.0.032	172530.0.032	50A @ 500V _{AC}
0.050	171530.0.050	172530.0.050	50A @ 500V _{AC}
0.063	171530.0.063	172530.0.063	50A @ 500V _{AC}
0.080	171530.0.080	172530.0.080	50A @ 500V _{AC}
0.100	171530.0.100	172530.0.100	50A @ 500V _{AC}
0.125	171530.0.125	172530.0.125	50A @ 500V _{AC}
0.160	171530.0.160	172530.0.160	50A @ 500V _{AC}
0.200	171530.0.200	172530.0.200	50A @ 500V _{AC}
0.250	171530.0.250	172530.0.250	50A @ 500V _{AC}
0.315	171530.0.315	172530.0.315	50A @ 500V _{AC}
0.400	171530.0.400	172530.0.400	50A @ 500V _{AC}
0.500	171530.0.500	172530.0.500	50A @ 500V _{AC}
0.630	171530.0.630	172530.0.630	50A @ 500V _{AC}
0.800	171530.0.800	172530.0.800	50A @ 500V _{AC}
1	171530.1	172530.1	50A @ 500V _{AC}
1.25	171530.1.25	172530.1.25	50A @ 500V _{AC}
With filling			
1.6	171530.1.6	172530.1.6	80A @ 500V _{AC}
2	171530.2	172530.2	80A @ 500V _{AC}
2.5	171530.2.5	172530.2.5	80A @ 500V _{AC}
3.15	171530.3.15	172530.3.15	80A @ 500V _{AC}
4	171530.4	172530.4	80A @ 500V _{AC}
5	171530.5	172530.5	80A @ 500V _{AC}
6.3	171530.6.3	172530.6.3	80A @ 500V _{AC}
8	171530.8	172530.8	80A @ 500V _{AC}
10	171530.10	172530.10	80A @ 500V _{AC}

Weight (kg per 100)
0.12
Units per package
10

Dimensions
[mm]

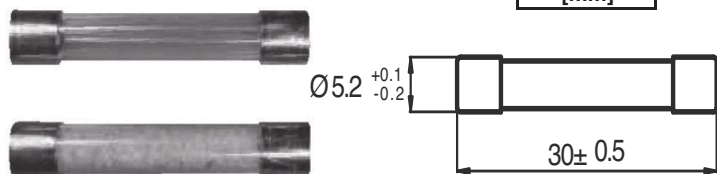

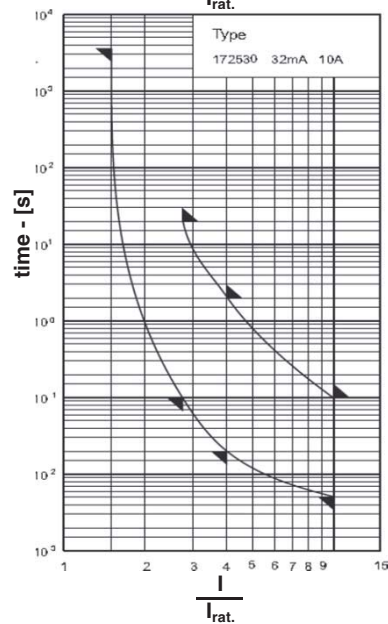
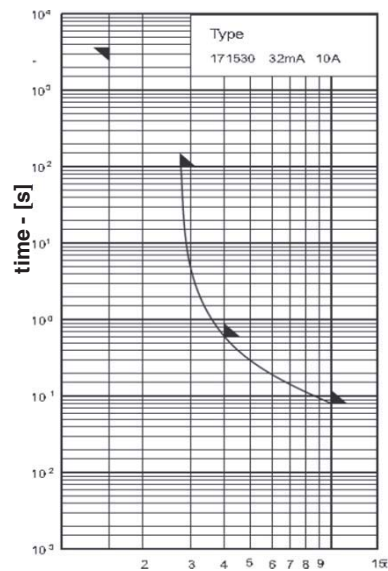

Time-Current Characteristics



	Rated current	Fusing Time Limits									
		1.5I _n		2.1I _n		2.75I _n		4I _n		10I _n	
		Min	Max	Min	Max	Min	Max	Min	Max	Min	I _{rat.}
171530	32mA - 10A	1h	—	—	—	—	100ms	—	600ms	—	80ms
172530	32mA - 10A	1h	—	—	—	50ms	30s	20ms	2s	5ms	100ms



FUSES

GZ   **Rated Voltage** [Un] **Rated Breaking Test** Voltage Capacity **Class** FF **Standard(s)** Special Type

700V_{AC} - 500V_{AC} 700V_{AC} - 500V_{AC} 50kA 

E180276

6.3mmx32mm - Ceramic tube w/ filler, end caps+ - brass, nickel plated

Rated current I_n [A]	Article Number	UL rec	Rated breaking current [A]	Voltage drop [mV]	Power dissipation @ $1I_n/1.2I_n$ [W]	Pre-arcing I^2t [A ² s]
0.100	7012540.0.100	✓	50kA @ 700V _{AC} ¹⁾	2 500	0.3	0.0009
0.125	7012540.0.125	✓	50kA @ 700V _{AC} ¹⁾	2 200	0.3	0.0017
0.160	7012540.0.160	✓	50kA @ 700V _{AC} ¹⁾	2 000	0.4	0.004
0.200	7012540.0.200	✓	50kA @ 700V _{AC} ¹⁾	900	0.2	0.01
0.250	7012540.0.250	✓	50kA @ 700V _{AC} ¹⁾	800	0.2	0.02
0.315	7012540.0.315	✓	50kA @ 700V _{AC} ¹⁾	700	0.3	0.04
0.400	7012540.0.400	✓	50kA @ 700V _{AC} ¹⁾	650	0.3	0.07
0.500	7012540.0.500	✓	50kA @ 700V _{AC} ¹⁾	650	0.4	0.12
0.630	7012540.0.630	✓	50kA @ 700V _{AC} ¹⁾	650	0.5	0.15
0.800	7012540.0.800	✓	50kA @ 700V _{AC} ¹⁾	600	0.5	0.23
1	7012540.1	✓	50kA @ 700V _{AC} ¹⁾	750	0.8	0.32
1.25	7012540.1.25	✓	50kA @ 700V _{AC} ¹⁾	700	0.9	0.20
1.6	7012540.1.6	✓	50kA @ 700V _{AC} ¹⁾	650	1.1	0.31
2	7012540.2	✓	50kA @ 700V _{AC} ¹⁾	650	1.4	0.64
2.5	7012540.2.5	✓	50kA @ 600V _{AC}	550	1.4	1.2
3.15	7012540.3.15	✓	50kA @ 600V _{AC}	500	1.6	2.0
4	7012540.4	✓	50kA @ 600V _{AC}	450	1.8	5.0
5	7012540.5	✓	50kA @ 500V _{AC}	400	2.0	10
6.3	7012540.6.3	✓	50kA @ 600V _{AC}	400	4	3.0
8	7012540.8	✓	50kA @ 600V _{AC}	350	4.5	6.5
10	7012540.10	✓	50kA @ 600V _{AC}	350	5	12
12.5	7012540.12.5	✓	50kA @ 500V _{AC}	300	7	18
16	7012540.16	✓	50kA @ 500V _{AC}	300	9	31
20	7012540.20	✓	50kA @ 500V _{AC}	300	11	46
25	7012540.25	✓	50kA @ 500V _{AC}	230	11	87

Weight (kg per 100)
0.24
Units per package
10

¹⁾20kA @ 500V_{DC}
For 6.3A and higher, consideration should be given to heat dissipation



Dimensions [mm]



IP - (1 000 pieces)
e.g. 70 125 40.16IP

Time-Current Characteristics

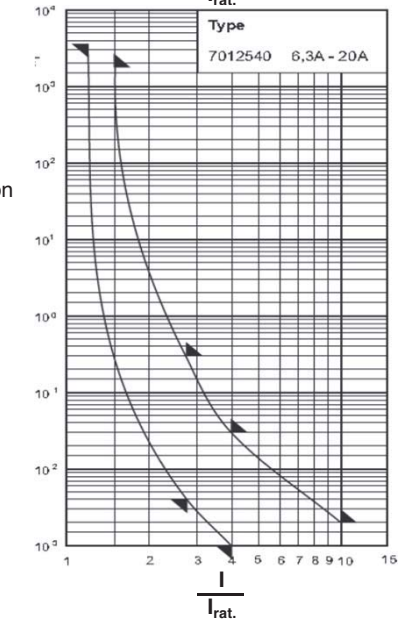
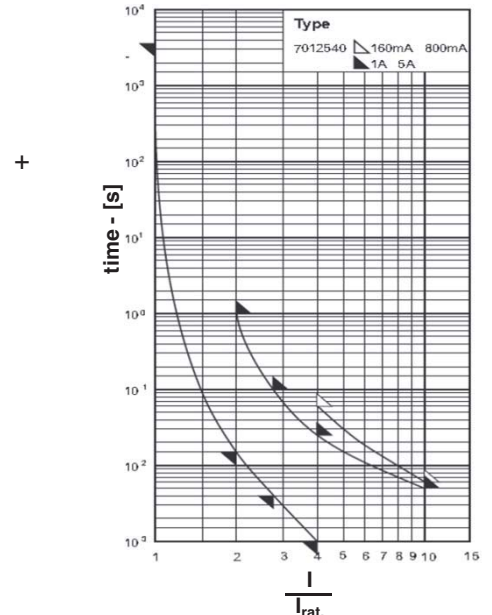

Rated current	Fusing Time Limits									
	$1I_n$		$1.2I_n$		$2.75I_n$		$4I_n$		$10I_n$	
	Min	Max	Min	Max	Min	Max	Min	Max	Min	Max
100mA - 800mA	1h	—	—	—	—	—	—	60ms	—	6ms
1A - 5A	1h	—	—	—	4ms	150s	1ms	25ms	—	5ms
6.3A - 20A	—	—	1h	—	4ms	300s	1ms	30ms	—	2ms

GZ

Rated Voltage [Un] 1000V_{AC} Rated Breaking Test Voltage 1000V_{AC} Capacity 30kA Class aR (FF) Standard(s) Special Type (Short circuit protection only)

E167295
6.3mmx32mm - Ceramic tube w /filler, end caps - brass, nickel plated

Rated current I _n [A]	Article Number	UL rec	Rated breaking current [A]	Voltage drop [mV]	Power dissipation @ 1.0I _n [W]	Pre-arcing I ² t [A ² s]
0.100	7017240.0.100	✓	30kA @ 1000V _{AC/DC} ¹	2 500	0.3	0.0009
0.125	7017240.0.125	✓	30kA @ 1000V _{AC/DC} ¹	2 200	0.3	0.0017
0.160	7017240.0.160	✓	30kA @ 1000V _{AC/DC} ¹	2 000	0.4	0.004
0.200	7017240.0.200	✓	30kA @ 1000V _{AC/DC} ¹	900	0.2	0.01
0.250	7017240.0.250	✓	30kA @ 1000V _{AC/DC} ¹	800	0.2	0.02
0.315	7017240.0.315	✓	30kA @ 1000V _{AC/DC} ¹	700	0.3	0.04
0.400	7017240.0.400	✓	30kA @ 1000V _{AC/DC} ¹	650	0.3	0.07
0.500	7017240.0.500	✓	30kA @ 1000V _{AC/DC} ¹	650	0.4	0.12
0.630	7017240.0.630	✓	30kA @ 1000V _{AC/DC}	650	0.5	0.15
0.800	7017240.0.800	✓	30kA @ 1000V _{AC/DC}	600	0.5	0.23
1	7017240.1	✓	30kA @ 1000V _{AC/DC}	750	0.8	0.32
1.6	7017240.1.6	✓	30kA @ 1000V _{AC/DC}	650	1.1	0.31
2	7017240.2	✓	30kA @ 1000V _{DC}	650	1.4	0.64

Time-Current Characteristics

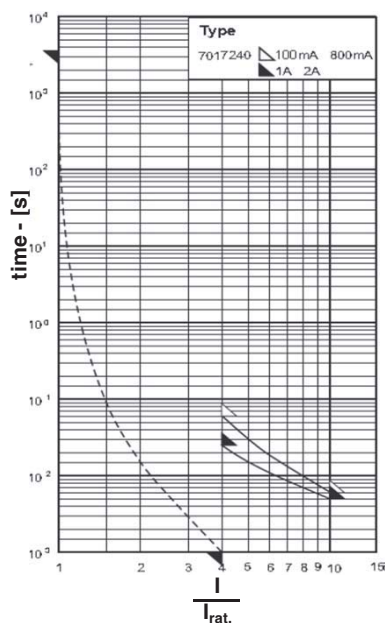

Weight (kg per 100)	¹⁾ Special breaking capacity - 50kA @ 1000V _{AC/DC} - without appro
Units per package	



IP - (1 000 pieces)
e.g. 70172 40.1.6IP



Dimensions [mm]



Rated current	Fusing Time Limits									
	1I _n		1.2I _n		2.75I _n		4I _n		10I _n	
	Min	Max	Min	Max	Min	Max	Min	Max	Min	Max
100mA - 800mA	1h	—	—	—	—	—	—	60ms	—	6ms
1A - 2A	1h	—	—	—	—	—	1ms	25ms	—	6ms

GZ   **Rated Voltage** [Un] **Rated Breaking Test** **Class** **Standard(s)**

400V_{AC} Voltage Capacity gRL IEC 60269-4
400V_{AC} 120kA VDE 0636 Part4

6.3mmx32mm - Ceramic tube w/ filler, end caps - brass, nickel plated 

Rated current I _n [A]	Article Number	UL rec	Rated breaking current [A]	Voltage drop [mV]	Power dissipation @ 1.0I _n [w]	Pre-arcing I ² t [A ² s]	Total I ² t [A ² s]
6.3	7006584.6.3	✓	120kA @ 400V _{AC}	190	1.2	1.8	11
8	7006584.8	✓	120kA @ 400V _{AC}	190	1.5	3.0	18
10	7006584.10	✓	120kA @ 400V _{AC}	180	1.8	5.1	31
12.5	7006584.12.5	✓	120kA @ 400V _{AC}	150	1.9	12	69
16	7006584.16	✓	120kA @ 400V _{AC}	150	2.3	20	120
20	7006584.20	✓	120kA @ 400V _{AC}	160	3.2	35	210

Weight (kg per 100)
Units per package

IP - (1 000 pieces)
e.g. 70 065 84.12.5IP

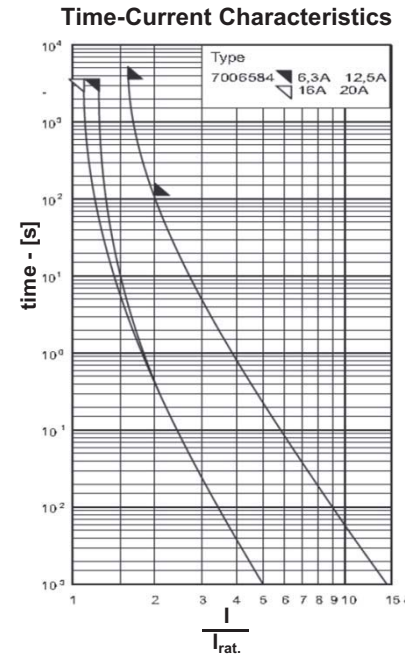

Dimensions [mm]

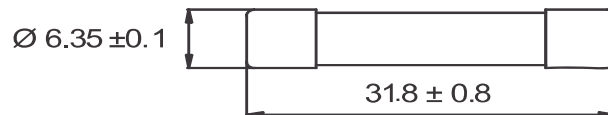

Rated current	Fusing Time Limits									
	1.1I _n		1.25I _n		1.6I _n		2.0I _n			
	Min	Max	Min	Max	Min	Max	Min	Max	Min	Max
6.3A - 12.5A	—	—	1h	—	—	1h	—	120s	—	—
16A - 20A	1h	—	—	—	—	1h	—	120s	—	—

GZ **RoHS** **Rated Voltage** [Un] **Rated Breaking Test** **Class** **Standard(s)**

250V_{AC} **Voltage** 250V_{AC} **Capacity** 35A /10 I_{rat} **F** **IEC 60269-2/4**

6.3mmx32mm - Glass tube, end caps - brass, nickel plated 

Rated current I _n [A]	Article Number	Rated breaking current [A]	Voltage drop [mV]	Power dissipation @ 1.15I _n [W]	Pre-arcing I ² t [A ² s]
0.050	189000.0.050	35A @ 250V _{AC}	9 600	0.7	0.0003
0.063	189000.0.063	35A @ 250V _{AC}	6 000	0.5	0.0005
0.080	189000.0.080	35A @ 250V _{AC}	5 000	0.6	0.001
0.100	189000.0.100	35A @ 250V _{AC}	4 500	0.7	0.0014
0.125	189000.0.125	35A @ 250V _{AC}	4 000	0.7	0.0034
0.160	189000.0.160	35A @ 250V _{AC}	3 500	0.8	0.007
0.200	189000.0.200	35A @ 250V _{AC}	650	0.2	0.02
0.250	189000.0.250	35A @ 250V _{AC}	650	0.3	0.04
0.315	189000.0.315	35A @ 250V _{AC}	600	0.3	0.08
0.400	189000.0.400	35A @ 250V _{AC}	500	0.3	0.15
0.500	189000.0.500	35A @ 250V _{AC}	450	0.3	0.32
0.630	189000.0.630	35A @ 250V _{AC}	400	0.4	0.26
0.800	189000.0.800	35A @ 250V _{AC}	350	0.4	0.57
1	189000.1	35A @ 250V _{AC}	300	0.5	1.1
1.25	189000.1.25	35A @ 250V _{AC}	300	0.6	2
1.6	189000.1.6	35A @ 250V _{AC}	300	0.7	3.3
2	189000.2	35A @ 250V _{AC}	250	0.8	6.2
2.5	189000.2.5	35A @ 250V _{AC}	220	0.9	13
3.15	189000.3.15	35A @ 250V _{AC}	200	1.1	24
4	189000.4	40A @ 250V _{AC}	200	1.3	40
5	189000.5	50A @ 250V _{AC}	180	1.4	80
6.3	189000.6.3	63A @ 250V _{AC}	170	1.6	150
8	189000.8	80A @ 250V _{AC}	160	2.0	240
10	189000.10	100A @ 250V _{AC}	150	2.3	500
12.5	189000.12.5	125A @ 250V _{AC}	140	2.5	650
16	189000.16	160A @ 250V _{AC}	130	2.8	1 250
20	189000.20	200A @ 250V _{AC}	130	4.0	1 600

Time-Current Characteristics

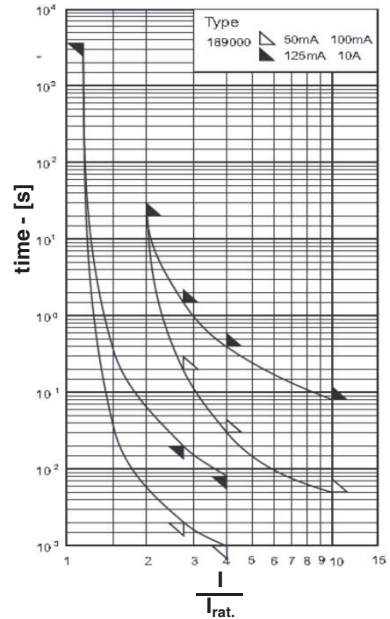

Weight (kg per 100)	For 6.3A and higher, consideration should be given to heat dissipation
Units per package	
10	



Dimensions [mm]

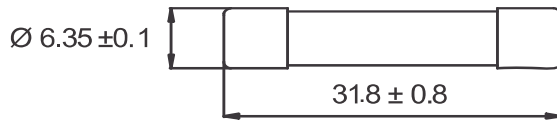

Rated current	Fusing Time Limits									
	1.5I _n		2I _n		2.75I _n		4I _n		10I _n	
	Min	Max	Min	Max	Min	Max	Min	Max	Min	Max
50mA - 100mA	—	—	—	20s	2s	200ms	1ms	30s	—	5ms
125mA - 20A	—	—	—	20s	20ms	1.5s	8ms	400ms	—	80ms

AK - with assembled leaded caps
 IP - (1 000 pieces)
 e.g. 189000.3.15IP

GZ  **Rated Voltage** [Un] **Rated Breaking Test** Voltage Capacity **Class** F **Standard(s)** Special Type

500V_{AC} - 440V_{AC} 500V_{AC} - 440V_{AC} 50kA / 1.5kA
 450V_{DC} - 125V_{DC} 450V_{DC} - 125V_{DC} 1.5kA

E 167295
 6.3mmx32mm - Ceramic tube w/ filler, end caps - brass, nickel plated



Rated current I _n [A]	Article Number	UL rec	Rated Breaking Current [A]	Voltage Drop [mV]	Dissipation @ 1.5I _n [W]	Pre-arcing I ² t [A ² s]
0.160	189020.0.160	✓	50kA @ 500V _{AC} ¹	7 000	2.5	0.0015
0.200	189020.0.200	✓	50kA @ 500V _{AC} ¹	6 500	2.9	0.0035
0.250	189020.0.250	✓	50kA @ 500V _{AC} ¹	6 000	3.4	0.0085
0.315	189020.0.315	✓	50kA @ 500V _{AC} ¹	1 000	0.9	0.036
0.400	189020.0.400	✓	50kA @ 500V _{AC} ¹	900	1.0	0.07
0.500	189020.0.500	✓	50kA @ 500V _{AC} ¹	800	1.1	0.19
0.630	189020.0.630	✓	50kA @ 500V _{AC} ¹	700	1.3	0.35
0.800	189020.0.800	✓	50kA @ 500V _{AC} ¹	600	1.4	0.49
1	189020.1	✓	50kA @ 500V _{AC} ¹	400	1.2	0.4
1.25	189020.1.25	✓	50kA @ 500V _{AC} ¹	300	1.3	0.8
1.6	189020.1.6	✓	50kA @ 500V _{AC} ¹	300	1.4	1.5
2	189020.2	✓	50kA @ 500V _{AC} ¹	280	1.6	2.5
2.5	189020.2.5	✓	50kA @ 500V _{AC} ¹	260	1.8	5
3.15	189020.3.15	✓	50kA @ 500V _{AC} ¹	240	2.3	9
4	189020.4	✓	50kA @ 500V _{AC} ¹	220	2.6	18
5	189020.5	✓	50kA @ 500V _{AC} ¹	190	2.9	40
6.3	189020.6.3	✓	50kA @ 500V _{AC} ¹	170	3.2	80
8	189020.8		1.5kA @ 500V _{AC} ²	160	3.7	150
10	189020.10		1.5kA @ 500V _{AC} ²	150	4.0	240
12.5	189020.12.5		1.5kA @ 500V _{AC} ²	140	5.5	500
16	189020.16		1.5kA @ 500V _{AC} ²	130	6.5	920
20	189020.20		1.5kA @ 440V _{AC} ²	120	8.4	1 500
25	189020.25		1.5kA @ 440V _{AC} ²	110	11	3 100

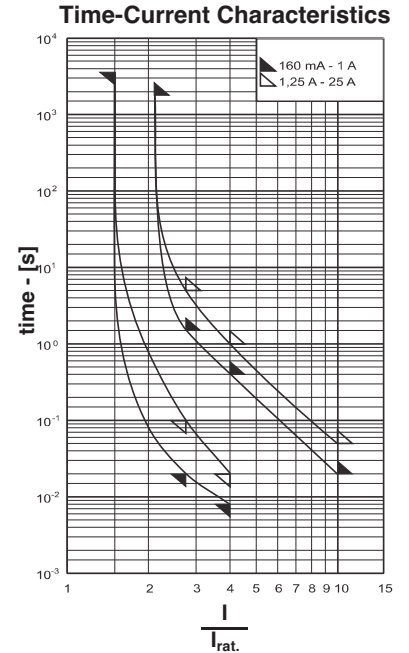

Weight (kg per 100)
Units per package
10

¹⁾ cosφ = 0.3, 1.5kA @ 450V_{DC}, resistive
²⁾ cosφ = 1, 1.5kA @ 125V_{DC}
 For 6.3A and higher, consideration should be given to heat dissipation

AK - with assembled leaded caps
 IP - (1 000 pieces)
 e.g. 189020.3.15AK



Dimensions [mm]

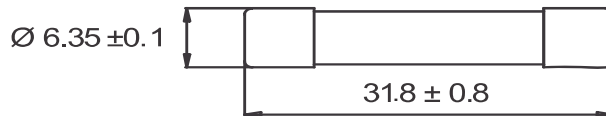

SMD version available 1A - 5A

Rated current	Fusing Time Limits									
	1.5I _n		2.1I _n		2.75I _n		4I _n		10I _n	
	Min	Max	Min	Max	Min	Max	Min	Max	Min	Max
160mA - 1A	1h	—	—	30m	20s	1.5s	8ms	400ms	—	20ms
1.25A - 25A	1h	—	—	30m	100ms	5s	20ms	1s	—	50ms

GZ **Rated Voltage** **Rated Breaking Test** **Class** **Standard(s)**
[Un] **Voltage** **Capacity** **F** **Special Type**
600V_{AC} **500V_{AC}** **50kA** **SIBA** **F**

6.3mmx32mm - Ceramic tube w/ filler, end caps - brass, nickel plated

Rated current I_n [A]	Article Number	Rated breaking current [A]	Power drop [mV]	Voltage dissipation @ $1.5I_n$ [w]	Pre-arcing I^2t [A ² s]
0.200	7009463.0.200	50kA @ 600V _{AC}	6 500	2.9	0.0035
0.400	7009463.0.400	50kA @ 600V _{AC}	900	1.0	0.07
0.500	7009463.0.500	50kA @ 600V _{AC}	800	1.1	0.19
0.800	7009463.0.800	50kA @ 600V _{AC}	600	1.4	0.49
1	7009463.1	50kA @ 600V _{AC}	400	1.2	0.4
2	7009463.2	50kA @ 600V _{AC}	280	1.6	2.5
3	7009463.3	50kA @ 600V _{AC}	260	2.2	7.5
5	7009463.5	50kA @ 600V _{AC}	190	2.9	40
7	7009463.7	50kA @ 600V _{AC}	150	3.8	100
10	7009463.10	50kA @ 600V _{AC}	150	4.0	240

Weight (kg per 100)
0.12
Units per package
10

For 7A and higher, consideration should be given to heat dissipation

AK - with assembled leaded caps
 IP - (1 000 pieces)
 e.g. 70 094 63.10IP

Time-Current Characteristics

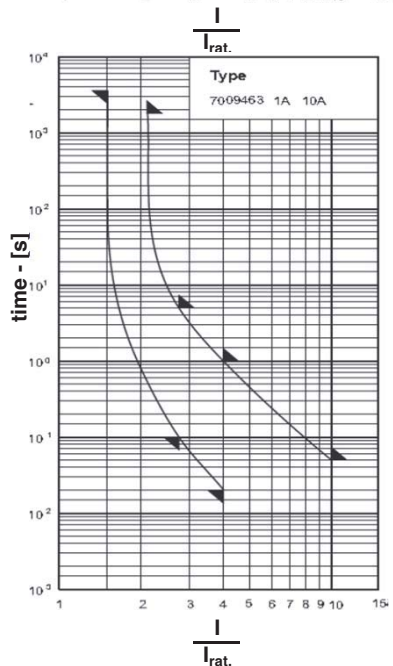
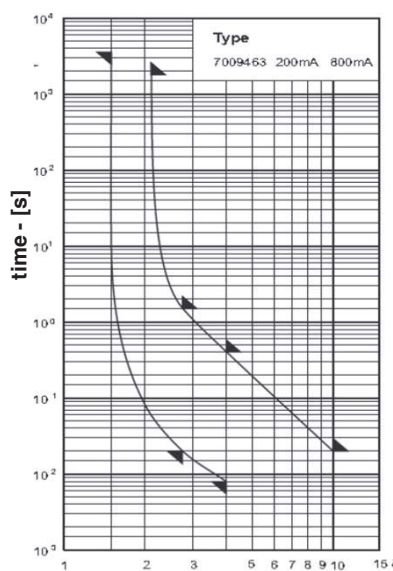

Dimensions [mm]

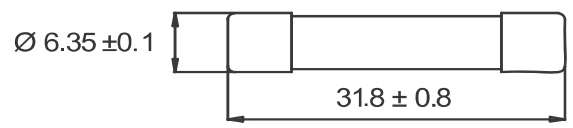

Rated current	Fusing Time Limits									
	1.5I _n		2.1I _n		2.75I _n		4I _n		10I _n	
	Min	Max	Min	Max	Min	Max	Min	Max	Min	Max
200mA - 800mA	1h	—	—	30m	20s	1.5s	8ms	400ms	—	20ms
1A - 10A	1h	—	—	30m	100ms	5s	20ms	1s	—	50ms

G RoHS Rated Voltage [Un] 250V_{AC} Rated Breaking Test Voltage 250V_{AC} Capacity 35A / 10 I_{rat} Class T Standard(s) Special Type

6.3mmx32mm - Glass tube, end caps - brass, nickel plated

Rated current I _n [A]	Article Number	Rated breaking current [A]	Voltage drop [mV]	Power dissipation @ 1.5I _n [W]	Pre-arcing I ² t [A ² s]
0.050	189100.0.050	35A @ 250V _{AC}	3 000	0.3	0.035
0.063	189100.0.063	35A @ 250V _{AC}	2 500	0.3	0.04
0.080	189100.0.080	35A @ 250V _{AC}	2 000	0.3	0.08
0.100	189100.0.100	35A @ 250V _{AC}	1 500	0.3	0.17
0.125	189100.0.125	35A @ 250V _{AC}	1 200	0.3	0.26
0.160	189100.0.160	35A @ 250V _{AC}	1 100	0.4	0.44
0.200	189100.0.200	35A @ 250V _{AC}	1 000	0.4	0.6
0.250	189100.0.250	35A @ 250V _{AC}	900	0.5	0.6
0.315	189100.0.315	35A @ 250V _{AC}	300	0.2	0.35
0.400	189100.0.400	35A @ 250V _{AC}	300	0.2	0.49
0.500	189100.0.500	35A @ 250V _{AC}	300	0.3	0.9
0.630	189100.0.630	35A @ 250V _{AC}	300	0.3	1.4
0.800	189100.0.800	35A @ 250V _{AC}	250	0.4	3.2
1	189100.1	35A @ 250V _{AC}	250	0.4	6.5
1.25	189100.1.25	35A @ 250V _{AC}	250	0.4	5
1.6	189100.1.6	35A @ 250V _{AC}	200	0.5	10
2	189100.2	35A @ 250V _{AC}	200	0.6	16
2.5	189100.2.5	35A @ 250V _{AC}	200	0.7	24
3.15	189100.3.15	35A @ 250V _{AC}	200	0.8	42
4	189100.4	40A @ 250V _{AC}	200	1.0	70
5	189100.5	50A @ 250V _{AC}	200	1.3	130
6.3	189100.6.3	63A @ 250V _{AC}	200	1.6	230
8	189100.8	80A @ 250V _{AC}	200	2.0	370
10	189100.10	100A @ 250V _{AC}	150	2.3	630
12.5	189100.12.5	125A @ 250V _{AC}	150	2.8	820
15	189100.15	150A @ 250V _{AC}	150	2.9	925
16	189100.16	160A @ 250V _{AC}	150	3.0	1 200
20	189100.20	200A @ 250V _{AC}	150	4.0	1 600

Time-Current Characteristics

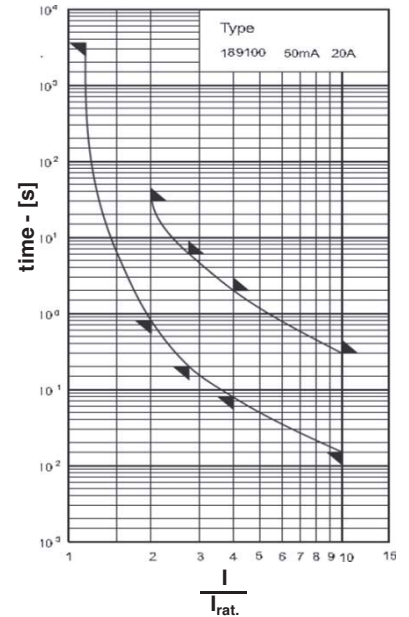

Weight (kg per 100)	For 6.3A and higher, consideration should be given to heat dissipation
Units per package	
10	



Dimensions [mm]



AK - with assembled leaded caps
 IP - (1 000 pieces)
 e.g. 189100.2IP

Rated current	Fusing Time Limits									
	1.5I _n		2I _n		2.75I _n		4I _n		10I _n	
	Min	Max	Min	Max	Min	Max	Min	Max	Min	Max
50mA - 20A	—	—	800ms	30s	200ms	6s	80ms	2s	15ms	300ms

GZ **Rated Voltage** **Rated Breaking Test** **Class** **Standard(s)**
[Un] **Voltage** **Capacity** **T** **Special Type**
 500V_{AC} - 250V_{AC} 500V_{AC} 1.5kA
 400V_{DC} 400V_{DC} 1.5kA
 6.3mmx32mm - Ceramic tube w/ filler, end caps - brass, nickel plated

Rated current I_n [A]	Article Number	UL	Rated breaking current [A]	Voltage drop [mV]	Power dissipation @ 1.5 I_n [W]	Pre-arcing I^2t [A ² s]
0.100	189140.0.100	rec	1.5kA @ 500V _{AC} ¹	3 600	1.3	0.04
0.125	189140.0.125	✓	1.5kA @ 500V _{AC} ¹	3 400	1.4	0.06
0.160	189140.0.160	✓	1.5kA @ 500V _{AC} ¹	3 000	1.5	0.1
0.200	189140.0.200	✓	1.5kA @ 500V _{AC} ¹	2 500	1.6	0.18
0.250	189140.0.250	✓	1.5kA @ 500V _{AC} ¹	2 000	1.7	0.25
0.315	189140.0.315	✓	1.5kA @ 500V _{AC} ¹	1 800	1.8	0.45
0.400	189140.0.400	✓	1.5kA @ 500V _{AC} ¹	1 600	2.0	0.45
0.500	189140.0.500	✓	1.5kA @ 500V _{AC} ¹	450	0.6	0.35
0.630	189140.0.630	✓	1.5kA @ 500V _{AC} ¹	400	0.7	0.49
0.800	189140.0.800	✓	1.5kA @ 500V _{AC} ¹	350	0.8	0.9
1	189140.1	✓	1.5kA @ 500V _{AC} ¹	350	0.9	1.4
1.25	189140.1.25	✓	1.5kA @ 500V _{AC} ¹	300	1.0	3.2
1.6	189140.1.6	✓	1.5kA @ 500V _{AC} ¹	200	1.1	5.2
2	189140.2	✓	1.5kA @ 500V _{AC} ¹	180	1.2	10
2.5	189140.2.5	✓	1.5kA @ 500V _{AC} ¹	160	1.3	19
3.15	189140.3.15	✓	1.5kA @ 500V _{AC} ²	150	1.4	37
4	189140.4	✓	1.5kA @ 500V _{AC} ²	140	1.5	68
5	189140.5	✓	1.5kA @ 500V _{AC} ²	135	2.2	80
6.3	189140.6.3	✓	1.5kA @ 500V _{AC} ²	110	2.2	215
8	189140.8	✓	1.5kA @ 500V _{AC} ²	110	2.6	370
10	189140.10	✓	1.5kA @ 500V _{AC} ²	100	3.0	620
12.5	189140.12.5	✓	1.5kA @ 500V _{AC} ³	100	3.5	1 300
16	189140.16	✓	1.5kA @ 500V _{AC} ³	100	4	2 500
20	189140.20	✓	1.5kA @ 440V _{AC} ³	100	6	3 400
25	189140.25	✓	1.5kA @ 440V _{AC} ³	100	8	5 600
32	189140.32	✓	1.5kA @ 250V _{AC} ³	80	10	3 900

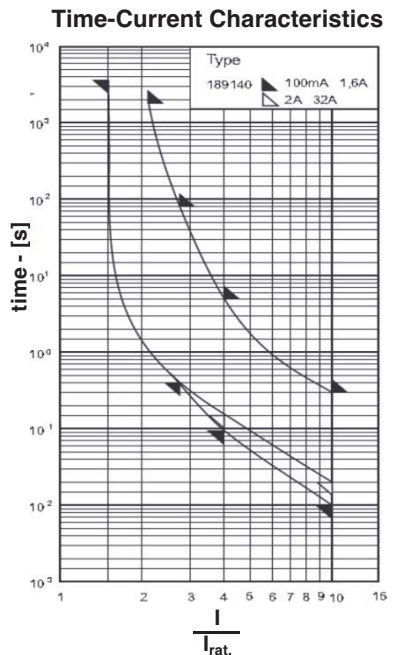

Weight (kg per 100) ¹ cosφ=1, 10kA @ 440V_{AC} cosφ=0.3, 1.5kA @ 400V_{DC} without approval
² cosφ=1, 10kA @ 440V_{AC} cosφ=0.3. **1.5kA @ 400V_{DC} - UL Recognized**
 Units per package ³ cosφ=1, 1.5kA @ 300V_{DC} without approval
 10 For 6.3A and higher, consideration should be given to heat dissipation

AK - with assembled leaded caps
 IP - (1 000 pieces)
 e.g. 189140.1.6IP



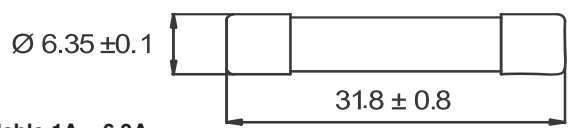

Dimensions [mm]



SMD version also available 1A - 6.3A

Rated current	Fusing Time Limits									
	1.5 I_n		2 I_n		2.75 I_n		4 I_n		10 I_n	
	Min	Max	Min	Max	Min	Max	Min	Max	Min	Max
100mA - 1.6A	1h	—	30m	—	400ms	80s	95ms	5s	10ms	300ms
2A - 32A	1h	—	30m	—	400ms	80s	150ms	5s	20ms	300ms

GZ   **Rated Voltage** [Un] **Rated Breaking Test** **Class** **Standard(s)**

E167295 **250V_{AC}** **250V_{AC}** **T/D** **UL 248-14**

6.3mmx32mm - Glass tube, end caps - brass, nickel plated **100A** **125V_{AC}** **10kA** **CSA C22.2 - No. 248-14**



Rated current I _n [A]	Article Number	Rated breaking current [A]	Voltage drop [mV]	Power dissipation @ 1.0I _n [mw]	Pre-arcing I ² t [A ² s]
0.300	189500.0.300	100A @ 250V _{AC} ¹	870	0.26	1.5
0.375	189500.0.375	100A @ 250V _{AC} ¹	840	0.32	2.5
0.400	189500.0.400	100A @ 250V _{AC} ¹	730	0.29	2.5
0.500	189500.0.500	100A @ 250V _{AC} ¹	660	0.33	5.4
0.600	189500.0.600	100A @ 250V _{AC} ¹	600	0.36	3.1
0.700	189500.0.700	100A @ 250V _{AC} ¹	580	0.41	4.5
0.800	189500.0.800	100A @ 250V _{AC} ¹	500	0.40	6.4
1	189500.1	100A @ 250V _{AC} ¹	450	0.45	13
1.25	189500.1.25	100A @ 250V _{AC} ¹	400	0.50	19
1.5	189500.1.5	100A @ 250V _{AC} ¹	370	0.56	25
1.6	189500.1.6	100A @ 250V _{AC} ¹	350	0.56	32
2	189500.2	100A @ 250V _{AC} ¹	330	0.66	55
2.5	189500.2.5	100A @ 250V _{AC} ¹	290	0.73	90
2.8	189500.2.8	100A @ 250V _{AC} ¹	270	0.76	120
3	189500.3	100A @ 250V _{AC} ¹	250	0.75	160
3.2	189500.3.2	100A @ 250V _{AC} ¹	220	0.70	350
4	189500.4	10kA @ 125V _{AC} ²	200	0.80	590
5	189500.5	10kA @ 125V _{AC} ²	200	1.0	600
6.25	189500.6.25	10kA @ 125V _{AC} ²	200	1.3	1 300
Weight (kg per 100)		1) 10kA @ 125V _{AC} , 100A@250V _{AC} - cosφ = 0.7 - 0.8			
Units per package		2) 10kA @ 125V _{AC} , cosφ = 0.7 - 0.8			
10					

Time-Current Characteristics

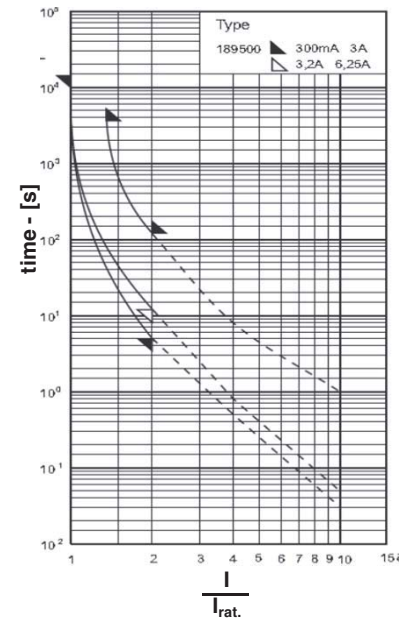

AK - with assembled leaded caps
 IP - (1 000 pieces)
 e.g. 189500.1.25IP



Dimensions [mm]



Rated current	Fusing Time Limits									
	1I _n		1.35I _n		2I _n					
	Min	Max	Min	Max	Min	Max	Min	Max	Min	Max
300mA - 3A	4h	—	—	1h	5s	—	—	—	—	—
3.2A - 6.25A	4h	—	—	1h	12s	—	—	—	—	—

GZ		Rated Voltage	Rated Breaking Test	Class	Standard(s)
		[Un] 400V _{DC}	Voltage 400V _{DC} Capacity 30kA	gPV	Following IEC 60269-4

6.3mmx32mm - Ceramic tube w/ filler, end caps - copper alloy, nickel plated

Rated current I_n [A]	Article Number	Rated breaking current [A]	Voltage drop [mV]	Power dissipation @ 1.0 I_n [W]	Pre-arcing I^2t [A ² s]	Total I^2t [A ² s]
1	7006526.1	30kA @ 400V _{DC}	600	0.60	0.58	1.1
1.25	7006526.1.25	30kA @ 400V _{DC}	500	0.63	1.1	2.2
1.6	7006526.1.6	30kA @ 400V _{DC}	375	0.6	3.2	6.5
2	7006526.2	30kA @ 400V _{DC}	300	0.6	7.1	15
2.5	7006526.2.5	30kA @ 400V _{DC}	270	0.7	14	30
3.15	7006526.3	30kA @ 400V _{DC}	250	0.8	11	22
4	7006526.4	30kA @ 400V _{DC}	220	0.9	23	50
5	7006526.5	30kA @ 400V _{DC}	210	1.1	42	85
6.3	7006526.6.3	30kA @ 400V _{DC}	200	1.3	83	150
8	7006526.8	30kA @ 400V _{DC}	175	1.4	150	300

Weight (kg per 100)
Units per package
10

AK - with assembled leaded caps
IP - (1 000 pieces)
e.g. 70 065 26.10IP

Time-Current Characteristics

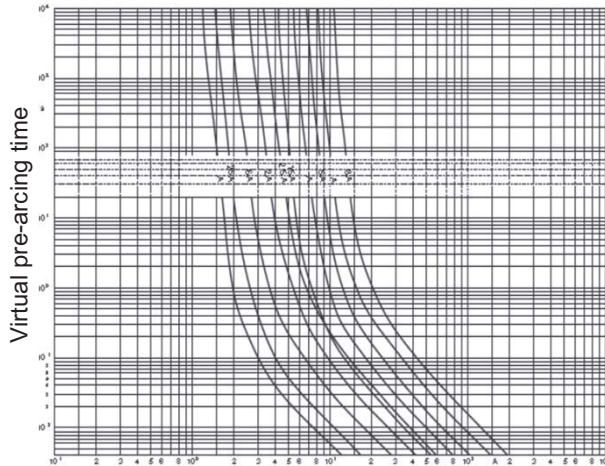

RMS Prospective Current



Dimensions [mm]

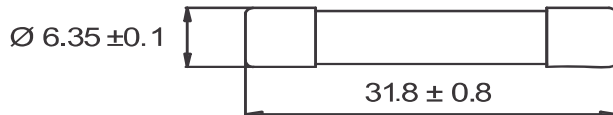

Rated current	Fusing Time Limits									
	1.1 I_n		1.45 I_n							
	Min	Max	Min	Max	Min	Max	Min	Max	Min	Max
1A - 8A	1h	—	—	1h	—	—	—	—	—	—

GZ Rated Voltage [Un] 500V_{AC} Rated Breaking Test Voltage 500V_{AC} Capacity 80A / 1.5kA Class M/F Standard(s) DIN 41686

RoHS

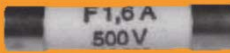

8mmx40mm - Glass tube(M), ceramic tube(F), end caps - brass, nickel plated

Rated current I _n [A]	Article Number	Rated breaking current [A]	Voltage drop [mV]	Power dissipation @ 1.0I _n [W]	Pre-arcing I ² t [A ² s]		
Class M							
0.032	183000.0.032	80A @ 500V _{AC}	2 300	Data On Request			
0.050	183000.0.050	80A @ 500V _{AC}	1 600				
0.063	183000.0.063	80A @ 500V _{AC}	1 300				
0.080	183000.0.080	80A @ 500V _{AC}	950				
0.100	183000.0.100	80A @ 500V _{AC}	700				
Class F							
0.125	183000.0.125	1.5kA @ 500V _{AC}	6 300				
0.160	183000.0.160	1.5kA @ 500V _{AC}	4 700				
0.200	183000.0.200	1.5kA @ 500V _{AC}	3 600				
0.250	183000.0.250	1.5kA @ 500V _{AC}	2 800				
0.315	183000.0.315	1.5kA @ 500V _{AC}	2 100				
0.400	183000.0.400	1.5kA @ 500V _{AC}	1 600				
0.500	183000.0.500	1.5kA @ 500V _{AC}	1 250				
0.630	183000.0.630	1.5kA @ 500V _{AC}	1 000				
0.800	183000.0.800	1.5kA @ 500V _{AC}	800				
1	183000.1	1.5kA @ 500V _{AC}	620				
1.25	183000.1.25	1.5kA @ 500V _{AC}	520				
1.6	183000.1.6	1.5kA @ 500V _{AC}	450				
2	183000.2	1.5kA @ 500V _{AC}	400				
2.5	183000.2.5	1.5kA @ 500V _{AC}	370				
3.15	183000.3.15	1.5kA @ 500V _{AC}	340				
4	183000.4	1.5kA @ 500V _{AC}	320				
5	183000.5	1.5kA @ 500V _{AC}	310				
6.3	183000.6.3	1.5kA @ 500V _{AC}	300				

Weight (kg per 100)
Units per Package

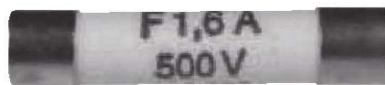

Dimensions [mm]

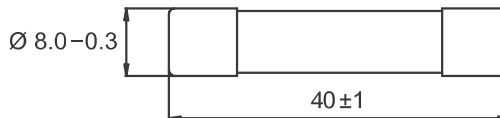

Time-Current Characteristics

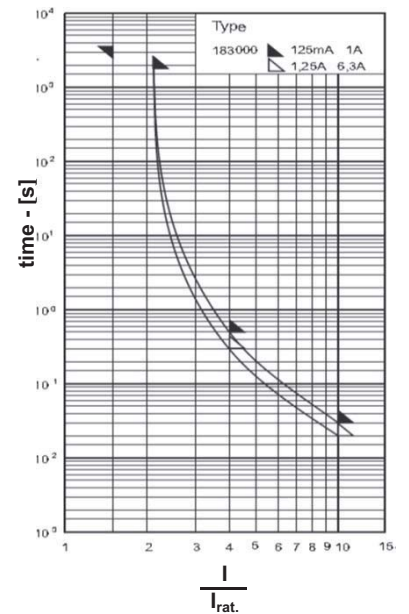
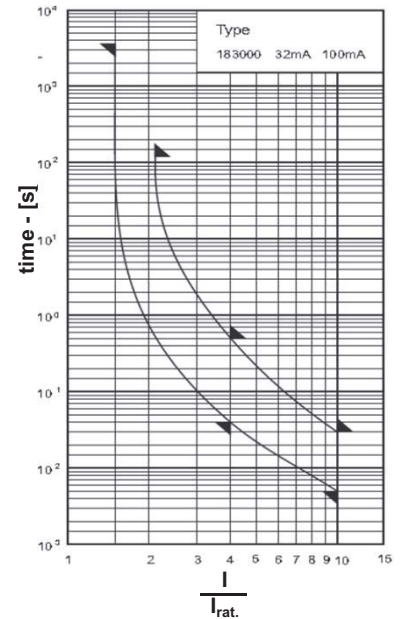

Rated current	Fusing Time Limits										
	1.5I _n		2.1I _n		2.75I _n		4I _n		10I _n		
	Min	Max	Min	Max	Min	Max	Min	Max	Min	Max	
32mA - 100mA	1h	—	—	—	2m	—	—	40ms	500ms	5ms	30ms
125mA - 1A	1h	—	—	30m	—	—	—	—	400ms	—	30ms
1.25A - 6.3A	1h	—	—	30m	—	—	—	—	300ms	—	20ms

GZ **RoHS** **Rated Voltage [Un]** **Rated Breaking Test Voltage** **Capacity** **Class M/F** **Standard(s)**

1.2kV_{AC} 3kV_{AC} 1.2kV_{AC} 3kV_{AC} 35A 35A F400mA F 2 A

8mmx50mm & 8mmx85mm - Ceramic tube, end caps - brass, nickel plated

Rated current I _n [A]	Article Number	Article Number	Rated breaking current [A]	Voltage drop maximum [mV]	Voltage drop maximum [mV]	
Class M				184000	185000	
0.032	184000.0.032	185000.0.032	184000 35A @ 1.2kV_{AC}	2 300	4 500	
0.050	184000.0.050	185000.0.050		1 900	3 000	
0.063	184000.0.063	185000.0.063		1 700	2 400	
0.080	184000.0.080	185000.0.080		1 500	1 900	
0.100	184000.0.100	185000.0.100		1 300	1 500	
Class F						
0.125	184000.0.125	185000.0.125		185000 35A @ 3kV_{AC}	9 500	17 500
0.160	184000.0.160	185000.0.160			8 000	14 000
0.200	184000.0.200	185000.0.200			7 000	12 000
0.250	184000.0.250	185000.0.250			6 000	10 500
0.315	184000.0.315	185000.0.315	5 000		9 000	
0.400	184000.0.400	185000.0.400	2 000		3 500	
0.500	184000.0.500	185000.0.500	950		1 600	
0.630	184000.0.630	185000.0.630	860		1 500	
0.800	184000.0.800	185000.0.800	760		1 300	
1	184000.1	185000.1	640		1 200	
1.25	184000.1.25	185000.1.25	540	1 000		
1.6	184000.1.6	185000.1.6	500	900		
2	184000.2	185000.2	460	800		
2.5 ¹	184000.2.5	185000.2.5	On Request			
3.15 ¹	184000.3.15	185000.3.15				
4 ¹	184000.4	185000.4				
5 ¹	184000.5					
6.3	184000.6.3					

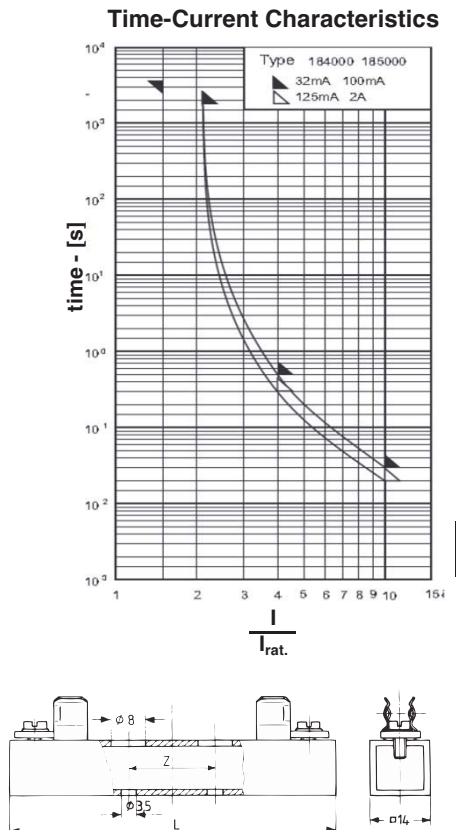

Weight (kg per 100)	Weight (kg per 100)	¹⁾ Non standard ratings also available
Units per package	Units per package	

Fuse base Article No.	Fuse	Rated voltage	Dimensions [mm]		Rated current [A]	Rated power [W]
			L	Z		
7103401	184000	1.2kV	75	20	6.3	4
7103701	185000	3kV	110	20	4	4

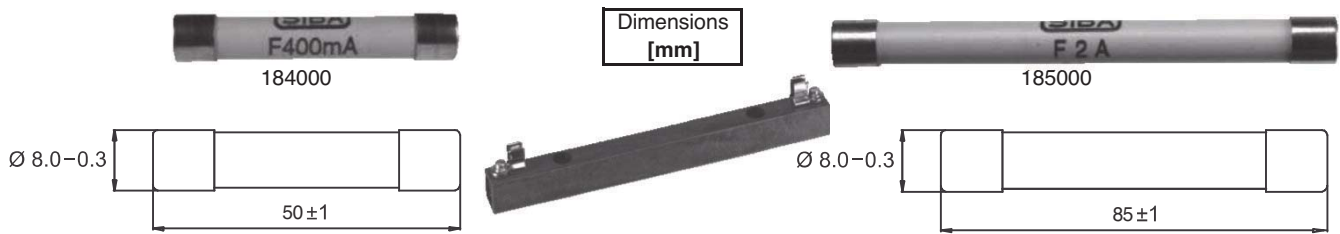

	Rated Current	Fusing Time Limits									
		1.5I _n		2.1I _n		2.75I _n		4I _n		10I _n	
		Min	Max	Min	Max	Min	Max	Min	Max	Min	Max
	32mA - 100mA	1h	—	—	30m	—	—	—	500ms	—	30ms
184000	125mA - 6.3A	1h	—	—	30m	—	—	—	300ms	—	20ms
185000	125mA - 4A	1h	—	—	30m	—	—	—	300ms	—	20ms

RoHS	Rated Voltage	Rated Breaking Test	Class	Standard(s)
	[Un]	Voltage	M/F	DIN 41683
	6kV _{AC} 10kV _{AC}	6kV _{AC} 10kV _{AC}	35A 35A	DIN 41684

8mmx120mm & 8mmx150mm - Ceramic tube, contacts - brass, nickel plated

Rated current I _n [A]	Article Number	Article Number	Rated breaking current [A]	Voltage drop maximum [mV]	Voltage drop maximum [mV]
Class M				186000	187000
0.032	186000.0.032	187000.0.032		6 000	14 000
0.050	186000.0.050	187000.0.050		4 400	8 500
0.063	186000.0.063	187000.0.063		3 800	6 500
0.080	186000.0.080	187000.0.080		3 200	5 000
0.100	186000.0.100	187000.0.100		2 900	4 000
Class F			186000 35A @ 6kV_{AC} 187000 35A @ 10kV_{AC}		
0.125	186000.0.125	187000.0.125		22 000	27 000
0.160	186000.0.160	187000.0.160		19 000	24 000
0.200	186000.0.200	187000.0.200		16 000	21 000
0.250	186000.0.250	187000.0.250		14 000	18 500
0.315	186000.0.315	187000.0.315		12 000	17 000
0.400	186000.0.400	187000.0.400		5 000	6 000
0.500	186000.0.500	187000.0.500		2 300	2 900
0.630	186000.0.630	187000.0.630		2 000	2 700
0.800	186000.0.800	187000.0.800		1 900	2 400
1	186000.1	187000.1		1 800	2 100
1.25	186000.1.25	187000.1.25		1 400	1 800
1.6	186000.1.6	187000.1.6		1 300	1 600
2	186000.2	187000.2		1 100	1 400
2.5 ¹	186000.2.5		On Request		
3.15 ¹	186000.3.15				
4 ¹	186000.4				

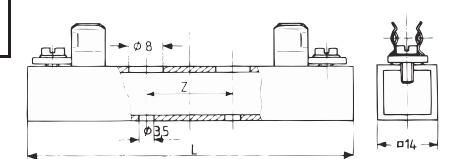
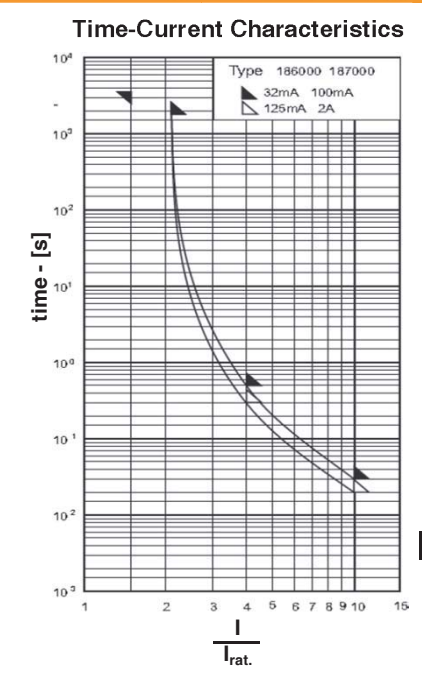

Fuse base Article No.	Fuse	Rated voltage	Dimensions [mm]		Rated current [A]	Rated power [W]
			L	Z		
7104001	186000	6kV	145	80	4	4
7104301	187000	10kV	175	100	2	4

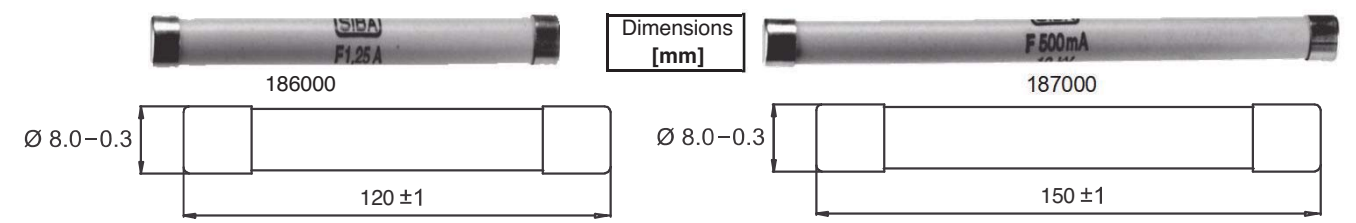

	Rated current	Fusing Time Limits									
		1.5I _n		2.1I _n		2.75I _n		4I _n		10I _n	
		Min	Max	Min	Max	Min	Max	Min	Max	Min	Max
	32mA - 100mA	1h	—	—	30m	—	—	—	500ms	—	30ms
186000	125mA - 6.3A	1h	—	—	30m	—	—	—	300ms	—	20ms
187000	125mA - 4A	1h	—	—	30m	—	—	—	300ms	—	20ms

GZHV / GSS Accessories



Miniature G High Voltage Fuses

Standard(s)
Company

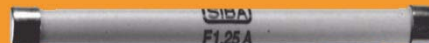

Ceramic tube w/ filler, contacts - copper alloy, silver plated

Article Number	Voltage rating	Dimensions	Current ratings	Class	Breaking capacity
7011509	3kV _{AC}	10mmx85mm	0.125A - 4A	F	150A
7011527	1.5kV _{AC} /1kV _{DC}	10mmx85mm	0.63A - 12.5A	T	10kA _{DC}
7011552	1.5kV _{AC} /1kV _{DC}	10mmx85mm	1A - 20A	F	1.5kA _{AC} / 300A _{DC}
7012927	1kV _{AC}	11mmx79mm	2A - 16A	T	15kA
7012952	1kV _{AC}	11mmx79mm	1A - 12A	F	15kA
7017182	1kV _{AC}	10mmx85mm	2A - 16A	aM	25kA
7002924	3kV _{AC}	12mmx100mm	0.5A - 10A	F	300A
7002927	3kV _{AC}	12mmx100mm	0.5A - 6.3A	T	300A
7003024	6kV _{AC}	12mmx150mm	0.5A - 4A	F	300A
7003124	10kV _{AC}	12mmx200mm	0.5A - 2A	F	300A



7103702

Fuse Holder				
Article Number	Voltage rating	Current ratings	Fuse size	Rated power
7103702	3kV	6.3A	10mmx85mm	4W



7102901
7103001
7103101

Fuse Base				
Article Number	Voltage rating	Current ratings	Fuse size	Rated power
7102901	3kV	6.3A	12mmx100mm	4W
7103001	6kV	4A	12mmx150mm	4W
7103101	10kV	2A	12mmx200mm	4W

GSS Accessories



Fuse holders for sub-miniature fuses 8.4mm x 7.6 mm with short leads

166602

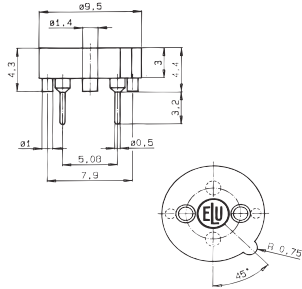

rated current
mounting
pin distance
hole
connections

6.3 A
printed circuit board
5.08 mm
Ø 1 mm
solderable

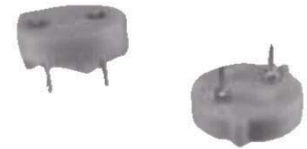

Fuse clips for miniature fuse links with 5mm & 6.3mm cap Ø

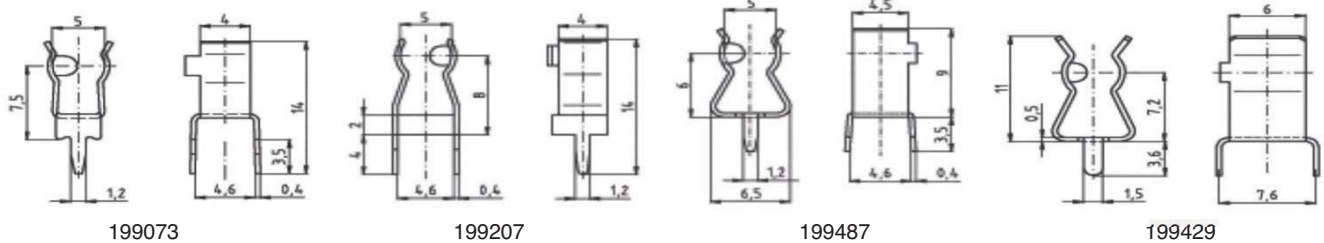

199073

199207

199487

199429

For Ø 5 mm

For or Ø 6.3 mm



rated current
mounting
material
connections

6.3A, Ø 5 mm
10A, Ø 6.3 mm
printed circuit board
brass, tinned
solderable



Fuse holders (fuse blocks) for miniature fuse links 5x20 mm

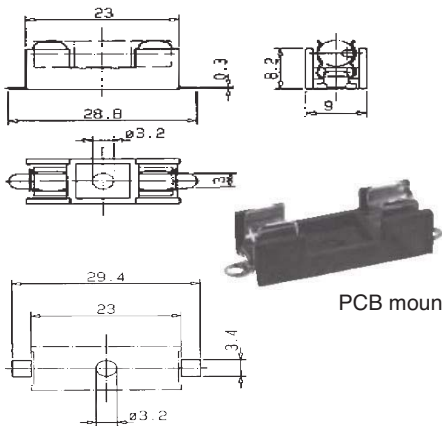

199011

rated voltage
rated current
rated power
mounting
connections
approvals VDE

250 V_{AC}, 300V_{DC}
6,3 A
1,6 W
printed circuit board, screw or rivet
solderable



PCB mounting pattern



Cover

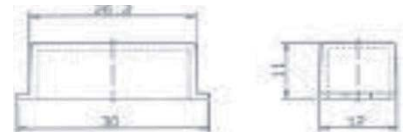

199012

GSS Accessories



RoHS



Fuse holders (fuse blocks) for miniature fuse links 5x20 mm

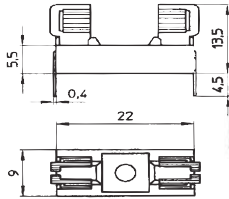

rated voltage
rated current
rated power
mounting
pin distance
hole
connections
cover 199016
approvals

250 V_{AC}
10A -UL, 6.3 - VDE
1.6 W
printed circuit board, screw or rivet
22.5 mm
Ø 1.5 mm
solder
thermoplastic, transparent
UL(rec) & VDE

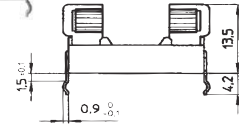

(soldeable only)
199015A

199015

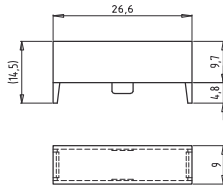

199016

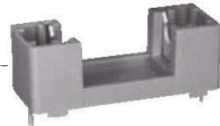
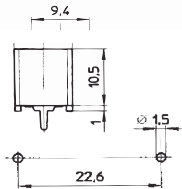
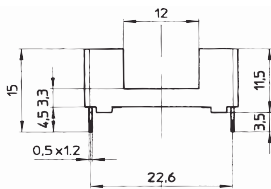

rated voltage
rated current
rated power
mounting
pin distance
hole
connections
cover 199016
approvals

250 V_{AC}
6.3 A
1.6 W
PCB thru hole
22.5 mm
Ø 1.5 mm
solderable
thermoplastic, green
UL(rec) & VDE

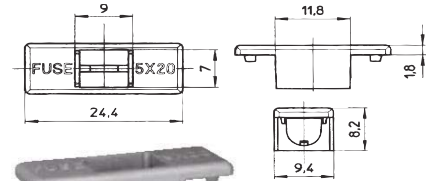

199019

199018

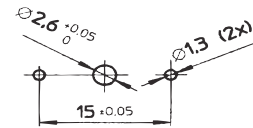
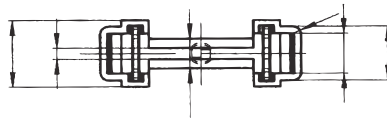
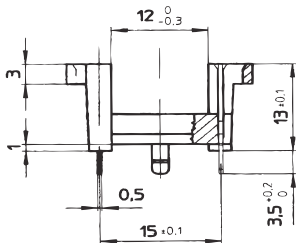

rated voltage
rated current
rated power
mounting
pin distance
hole
connections

250 V_{AC}
6,3 A
1,6 W
printed circuit board
15 mm
Ø 1.3 mm / 2.6mm
solderable

199060

GSS Accessories



RoHS



Fuse holders (fuse blocks) for miniature fuse links 5x20 mm

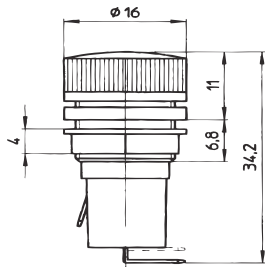

199030

approvals UL(rec) & VDE
 mounting panel
 hole 13mm
 locating lug
 locknut SW14
 fuse carrier screw cap
 connections 2.8mm plug connector or solderable

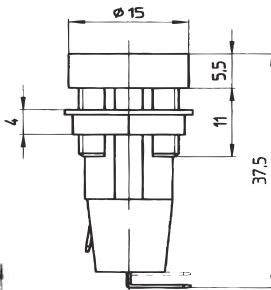
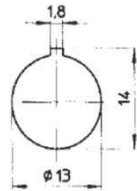

199035

approvals UL(rec) & VDE
 mounting panel
 hole 12.7mm
 locating lug
 locknut SW14
 fuse carrier screw cap
 connections 2.8mm plug connector or solderable

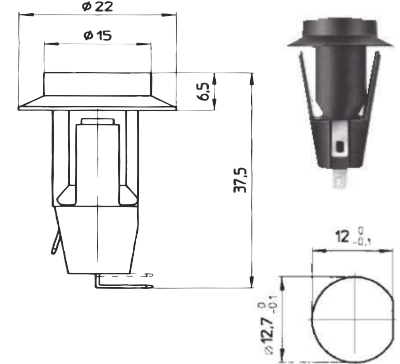
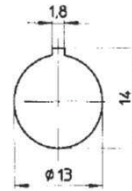

199040

approvals UL(rec) & VDE
 mounting panel (0.8mm - 2.5m)
 hole 12.7mm
 locating lug
 snap-in
 fuse carrier screw cap
 connections 2.8mm plug connector or solderable

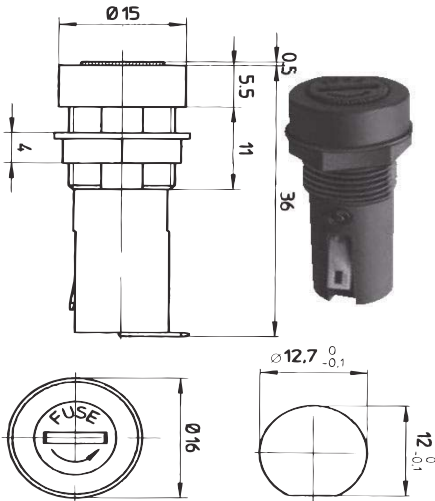

199055

mounting panel
 hole 12.7mm
 locating lug
 locknut SW14
 fuse carrier bayonet cap
 connections solderable
 approvals UL(rec) & VDE

rated voltage	250 V
rated current	10A
rated power	2.5 W
dielectric strength	3 kV
protection standard	IP 40
shock safe category	PC2

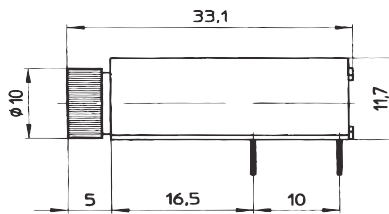

199050

mounting PCB thru hole
 pin distance 10mm
 via hole Ø 1.3 +0.1 mm
 fuse carrier bayonet cap
 connections solderable
 approvals UL(rec) & VDE

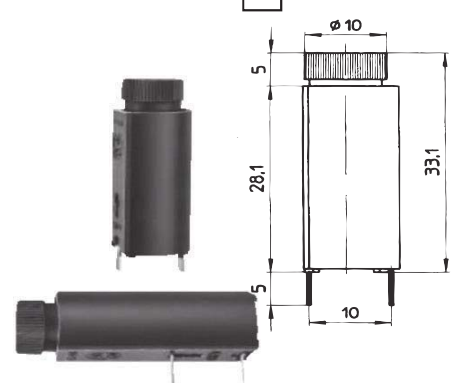

199045

mounting PCB thru hole
 pin distance 10mm
 via hole Ø 1.3 +0.1 mm
 fuse carrier bayonet cap
 connections solderable
 approvals UL(rec) & VDE

GSS Accessories



Fuse holders (fuse blocks) for miniature fuse links 5x20 mm

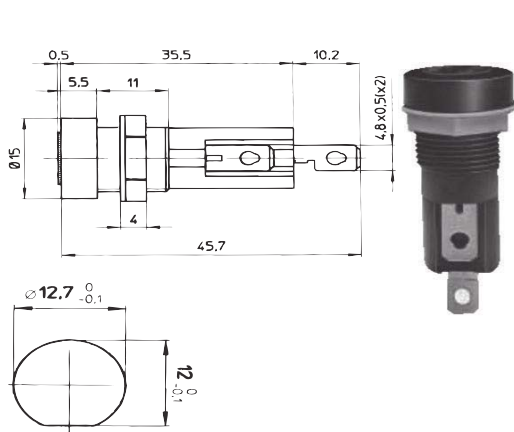

199070

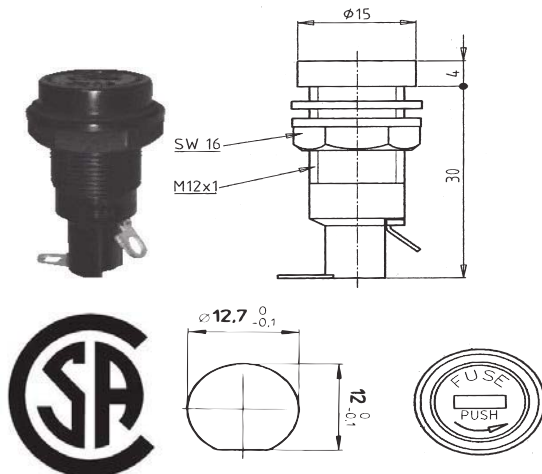

199090

rated voltage	250 V
rated current	6.3 VDE / 10A UL/CSA
rated power	2.5 W
dielectric strength	3 kV
protection standard	IP 40
shock safe category	PC2
mounting	panel
hole	12.7mm
locating lug	
locknut	SW14
fuse carrier	bayonet cap
connections	4.8mm plug connector
approvals	UL(rec) & VDE

rated voltage	250 V
rated current	6.3A VDE & SEMKO / 10A UL/CSA
rated power	
dielectric strength	3 kV
protection standard	IP 40
shock safe category	PC2
mounting	panel
hole	12.7mm
locating lug	
locknut	SW16
fuse carrier	bayonet cap
connections	solderable
approvals	UL(rec) CSA (10A), VDE & SEMKO



In line fuse holders for miniature fuse links 5x20 mm

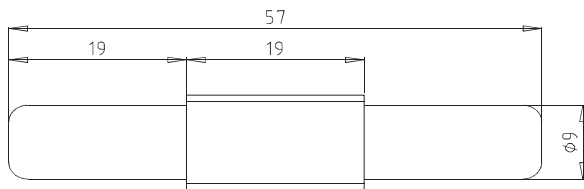

199080

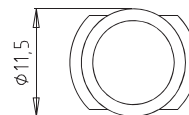

rated voltage
rated current
rated power
mounting
locking
connections

250 V
6.3A
1.6 W
in line fuse holder
bayonet type
solderable

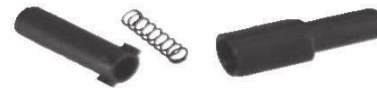

GSS Accessories



RoHS



Fuse holders (fuse blocks) for miniature fuse links 5x20mm / 6.3x32mm

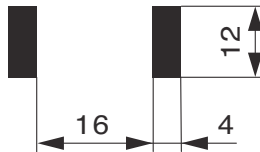
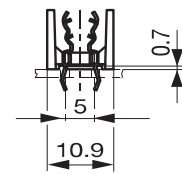
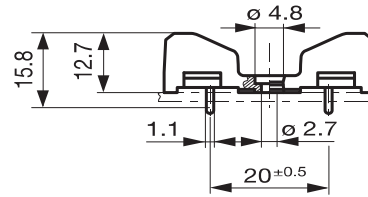
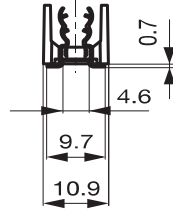
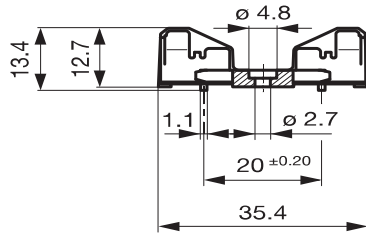

Solder Pad

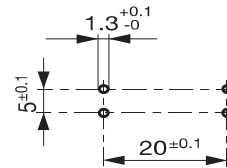

Drill Pattern



199511

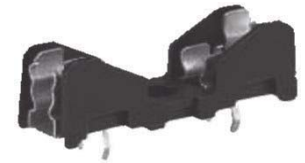

199537

rated voltage 500V (VDE) / 600V_{AC/DC}(UL/CSA)
 rated current 10A (VDE) / 16A (UL/CSA)
 rated power 4 W
 dielectric strength 3 kV
 mounting PCB surface mount
 fixing rivet or screw
 connections solderable
 approvals UL(rec) & VDE

rated voltage 500V (VDE) / 600V_{AC/DC}(UL/CSA)
 rated current 10A (VDE) / 16A (UL/CSA)
 rated power 4 W
 dielectric strength 3 kV
 mounting PCB thru hole
 fixing rivet or screw
 connections solderable
 approvals UL(rec) & VDE

GSS Accessories



RoHS



Fuse holders (fuse blocks) for miniature fuse links 6.3x32mm

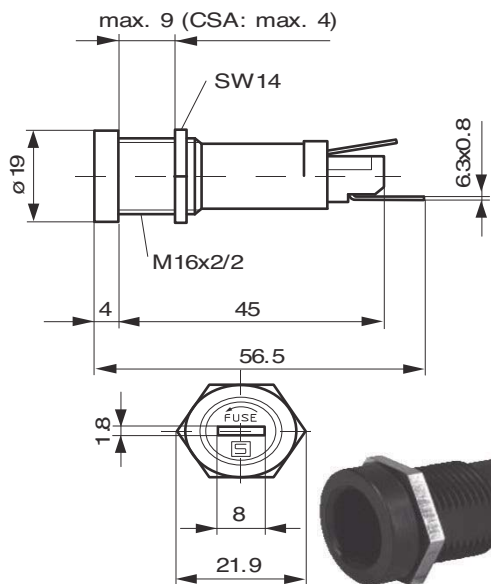

199530

Hole Pattern

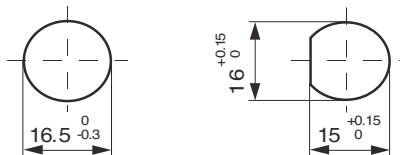

199531

rated voltage
 rated current
 rated power
 dielectric strength
 protection standard
 shock safe category
 mounting
 hole
 locating lug
 locknut
 fuse carrier
 connections
 approvals

500V (VDE) / 600V_{AC/DC}(UL/CSA)
 10A (VDE) / 20A (UL/CSA)
 4 W @ 10A
 3 kV
 IP 40
 PC2
 front panel
 16.5mm

 bayonet cap
 6.3x8mm plug connector
 UL(rec) & VDE

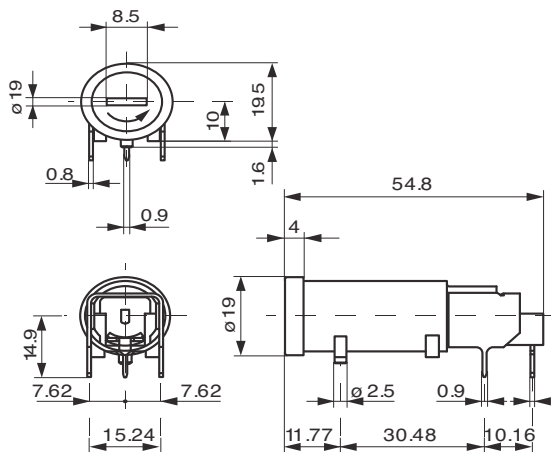

199550

rated voltage
 rated current
 rated power
 dielectric strength
 protection standard
 shock safe category
 mounting
 fuse carrier
 connections
 approvals

500V (VDE) / 600V_{AC/DC}(UL/CSA)
 16A (VDE) / 30A (UL/CSA)
 4 W @ 16A
 3 kV
 IP 40
 PC2
 PCB
 screw cap
 solderable THT
 UL(rec) & VDE

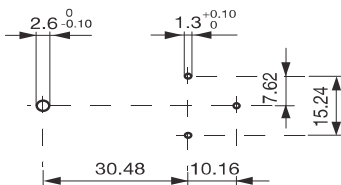

199552

GSS



RoHS

Fuse holders (fuse blocks) for miniature fuse links 6.3x32mm

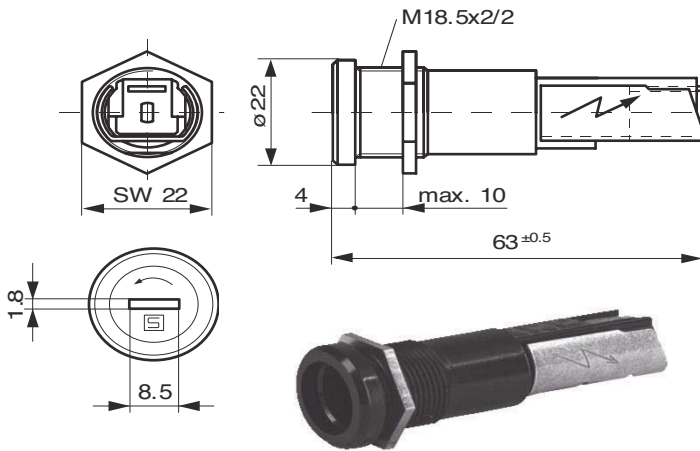

199555

approvals UL(rec), VDE
 rated voltage 500V (VDE) / 600V_{AC/DC} (UL/CSA)
 rated current 16A (VDE) / 30A (UL/CSA)
 rated power 4 W @ 16A
 dielectric strength 3 kV
 protection standard IP 40
 shock safe category PC2
 mounting panel
 fixing nut
 fuse carrier screw cap
 connections 6.3x0.8mm plug connector
 approvals UL(rec) & VDE

199552



RoHS

Fuse holders (fuse blocks) for miniature fuse links 5x20mm

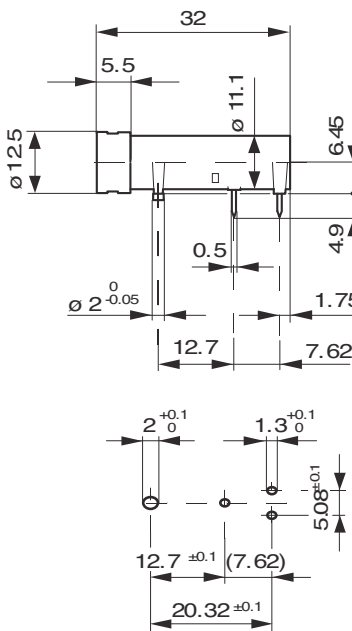

7100127

rated voltage 250V_{AC}
 rated current 10A (VDE) / 16A (UL/CSA)
 rated power 2.5 W @ 10A
 dielectric strength 3 kV
 protection standard IP 40
 shock safe category PC2
 mounting PCB thru hole
 pin distance 7.62x5.08mm
 via hole Ø 1.3 +0.1 mm
 fuse carrier bayonet cap
 connections solderable
 approvals UL(rec) & VDE

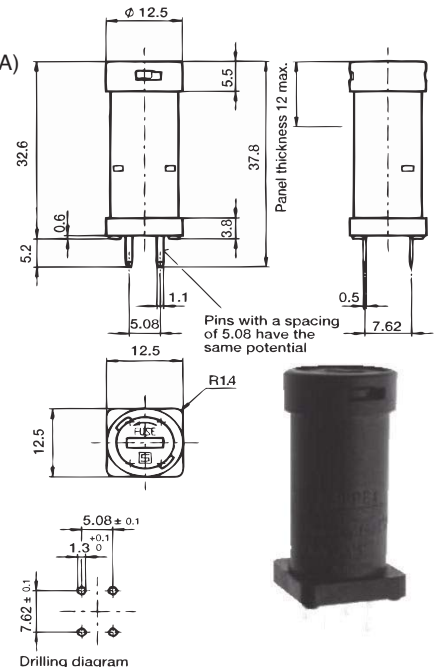

7100128

GSS Accessories



Fuse holders (fuse blocks) for miniature fuse links 5x20mm

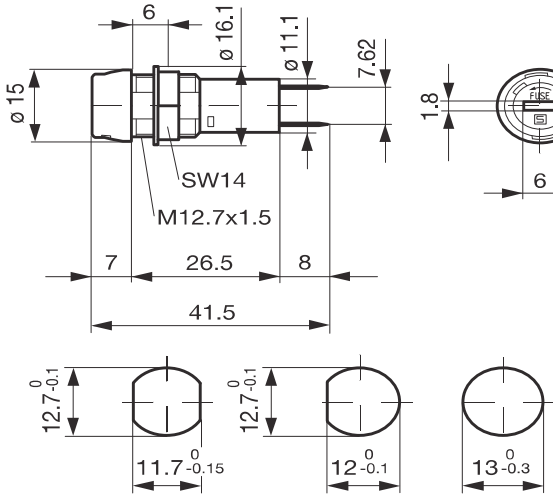

rated voltage	250 V _{AC}
rated current	10 VDE / 16A UL/CSA
rated power	2.5 W @ 10A
dielectric strength	3 kV
protection standard	IP 40
shock safe category	PC2
mounting	panel
hole	13mm
distortion protection	
locknut	M12.7x1.5
fuse carrier	bayonet cap
connections	solderable
approvals	UL(rec) & VDE

7100129

G



Press on leads for miniature fuse links 5x20mm and 6.3x32mm

Ø 5mm

Ø 6.3mm

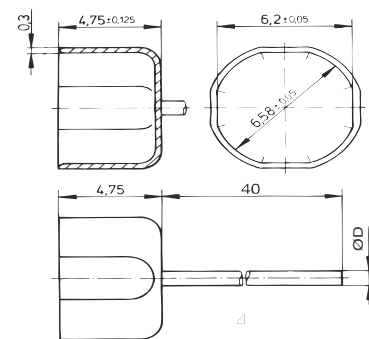
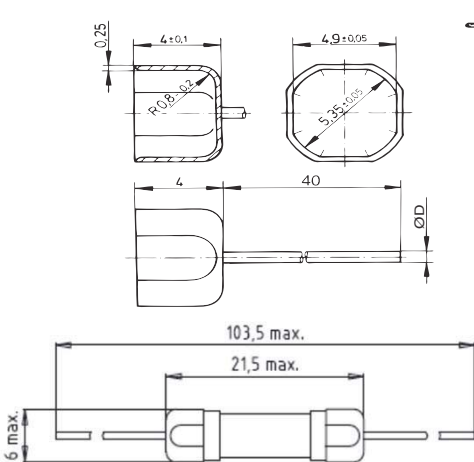

Ø 5mm		
204000 Max 6.3A	D=0.65mm	
204001 Max 10A	D=0.8mm	
204002 Max 16A	D=1mm	
Ø 6.3mm		
204100 Max 12.5A	D=0.8mm	
204101 Max 20A	D=1mm	

SIBA LLC

29 Fairfield Place
West Caldwell, New Jersey 07006

Phone 1-973-575-7422
Fax 1-973-575-5858

portal: www.siballc.net
e-mail: info@sibafuse.com

GSS Accessories



RoHS



Fuse holders (fuse blocks) for miniature fuse links 5x20mm or 6.3x32mm

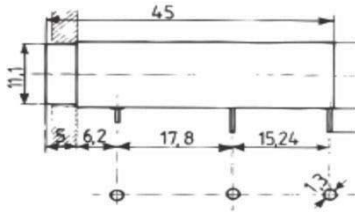

7100114

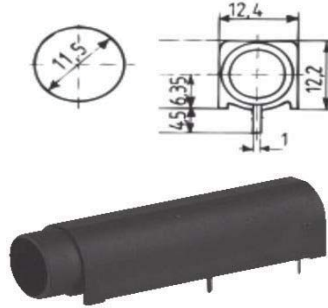

rated voltage 250V_{AC}
 rated current 10A (VDE) / 16A (UL/CSA)
 rated power 2.5 W @ 10A(5x20mm)
 rated power 3.2 W @ 10A(6.3x32mm)
 dielectric strength 3 kV
 protection standard IP 40
 shock safe category PC2
 mounting PCB
 pin distance 15.24mm
 via hole Ø 1.3 +0.1 mm
 fuse carrier bayonet cap
 connections solder
 approvals UL(rec), CSA & VDE

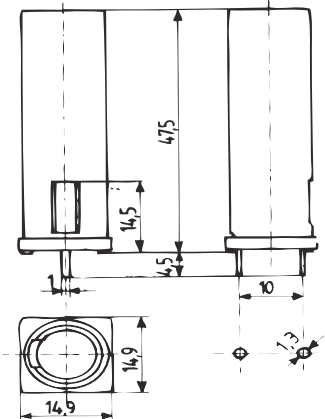

7100116

rated voltage 250V_{AC}
 rated current 10A (VDE) / 16A (UL/CSA)
 rated power 2.5 W @ 10A(5x20mm)
 rated power 3.2 W @ 10A(6.3x32mm)
 dielectric strength 3 kV
 protection standard IP 40
 shock safe category PC2
 mounting PCB
 pin distance 10mm
 via hole Ø 1.3 +0.1 mm
 fuse carrier bayonet cap
 connections solder
 fuse carrier bayonet cap
 connections solder
 approvals UL(rec), CSA & VDE

5x20mm



7200108

6.3x32mm



7200109

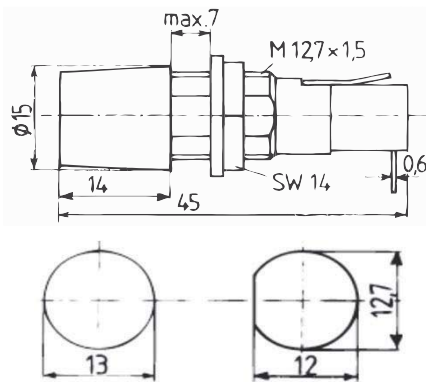

7100123

rated voltage 250V
 rated current 10A (VDE) / 20A (UL)
 rated power 4 W @ 10A
 dielectric strength 3 kV
 protection standard IP 40
 shock safe category PC2
 mounting panel
 hole 13mm
 locating lug
 locknut
 fuse carrier bayonet cap
 connections solder
 approvals UL(rec) 20A, VDE 10A

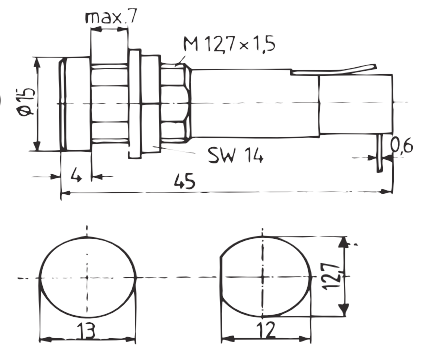

7100124

rated voltage 250V
 rated current 10A (VDE) / 20A (UL)
 rated power 4 W @ 10A
 dielectric strength 3 kV
 protection standard IP 40
 shock safe category PC2
 mounting panel
 hole 13mm
 locating lug
 locknut
 fuse carrier bayonet cap
 connections solder
 approvals UL(rec) 20A, VDE 10A